

oak30



contanot®
scale di ogni tempo



Copyright by Albini & Fontanot S.p.A., first publication 18 april 2011



10 mm
13 mm
19 mm

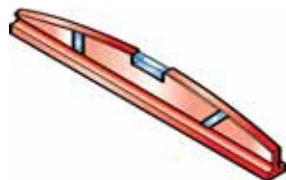

3 mm
5 mm
6 mm
10 mm

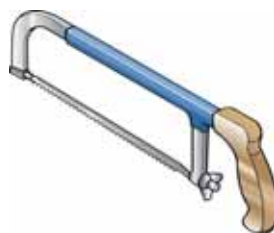

PH 2



Ø 2,5 mm
Ø 6,5 mm



Ø 8 x 120 mm
Ø 14 x 150 mm

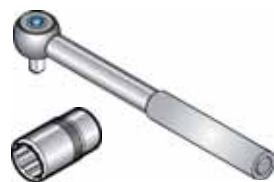

10 mm
13 mm
19 mm

1

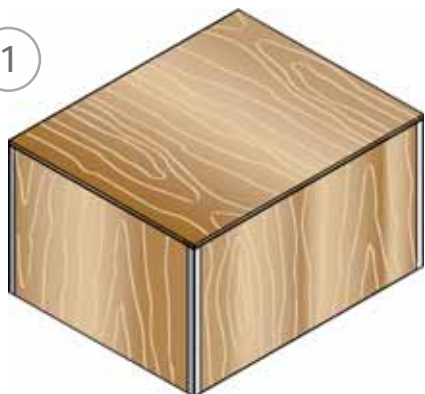

2

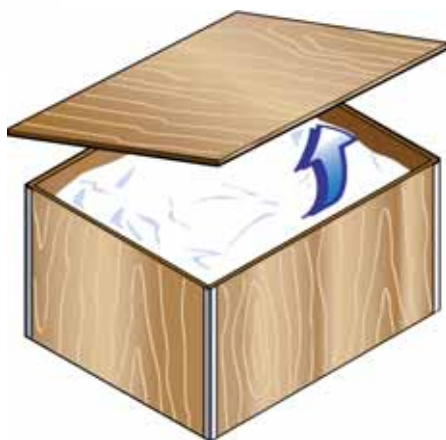

3

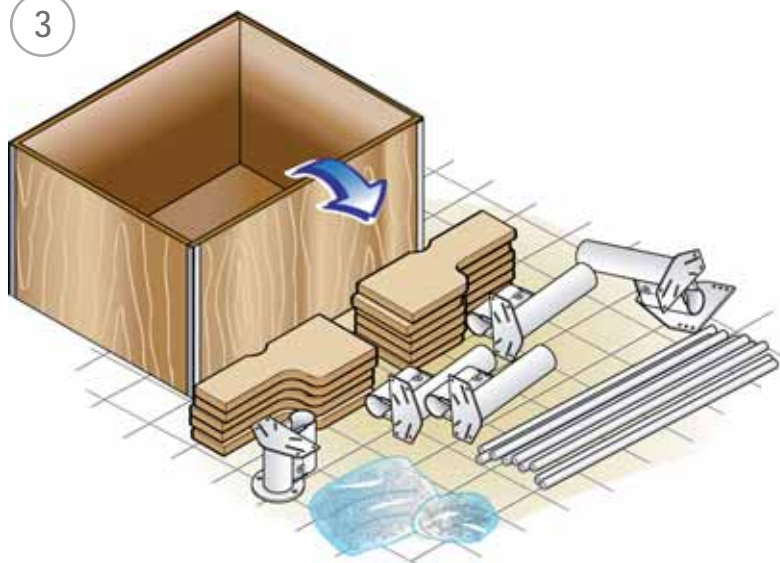

11	12	13	15
2	3	3	4

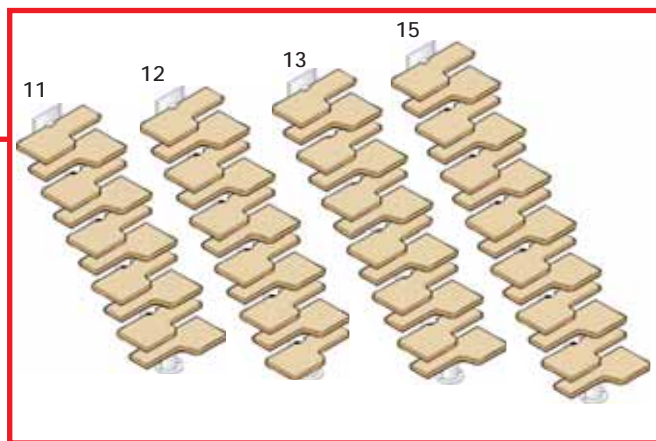

A22



11	12	13	15
3	4	4	4

A37



11	12	13	15
2	2	2	2

B02



11	12	13	15
23	25	27	31

B12



11	12	13	15
4	4	4	4

B33



11	12	13	15
2	3	3	3

B71



11	12	13	15
18	20	22	26

B75



11	12	13	15
36	40	44	52

B82



11	12	13	15
10	11	12	14

C03



11	12	13	15
11	12	13	15

C13



11	12	13	15
22	24	26	30

C14



11	12	13	15
22	24	26	30

C15



11	12	13	15
18	20	22	26

C39



11	12	13	15
4	4	4	4

C49



11	12	13	15
23	25	27	31

C50



11	12	13	15
1	1	1	1

C57



11	12	13	15
40	44	48	56

C58



11	12	13	15
4	4	4	4

C63



11	12	13	15
11	12	13	15

C64



11	12	13	15
24	26	28	32

C65



11	12	13	15
11	12	13	15

C66



11	12	13	15
11	12	13	15

D72



11	12	13	15
2	3	3	3

F01



11	12	13	15
1	1	1	1

F08



11	12	13	15
2	2	2	2

F09



11	12	13	15
1	1	1	1

F23



11	12	13	15
22	24	26	30

L41

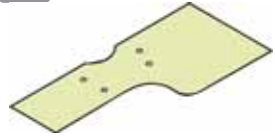

11	12	13	15
5	6	6	7

L44

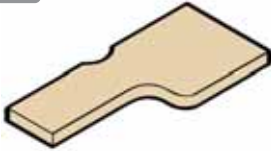

11	12	13	15
5	5	6	7

N16



11	12	13	15
1	1	1	1

N17



11	12	13	15
7	1	1	1

N18



11	12	13	15
7	8	9	11

N19



11	12	13	15
1	1	1	1

X01



4

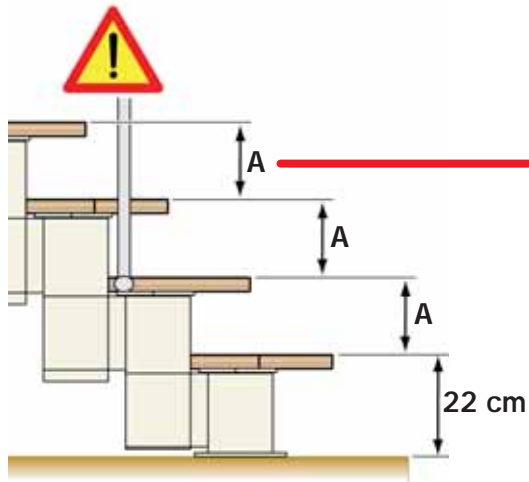

11 (N)



12 (N)



13 (N)



15 (N)

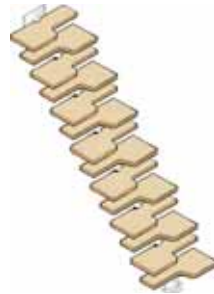

$$A = H - 22 \text{ cm} / N - 1$$

(A = 19 ÷ 23,5 cm)

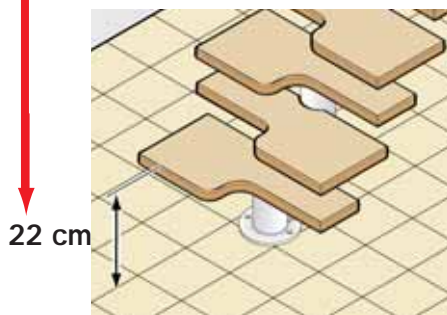
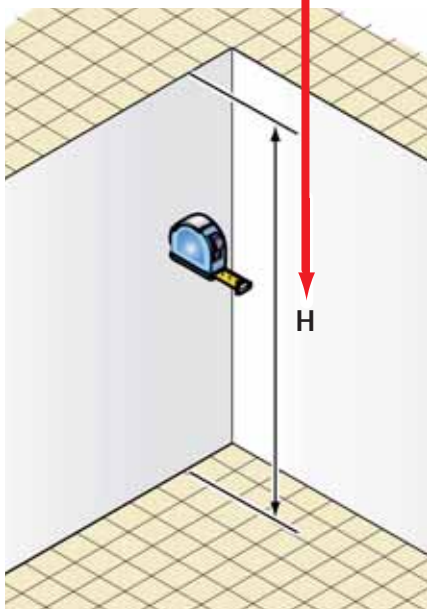

5

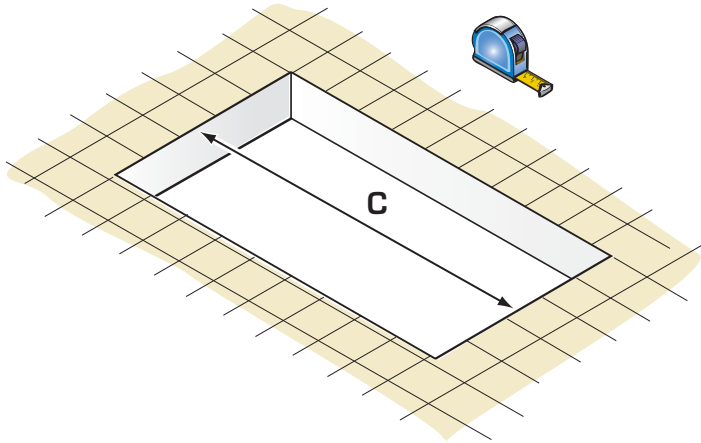

6 a

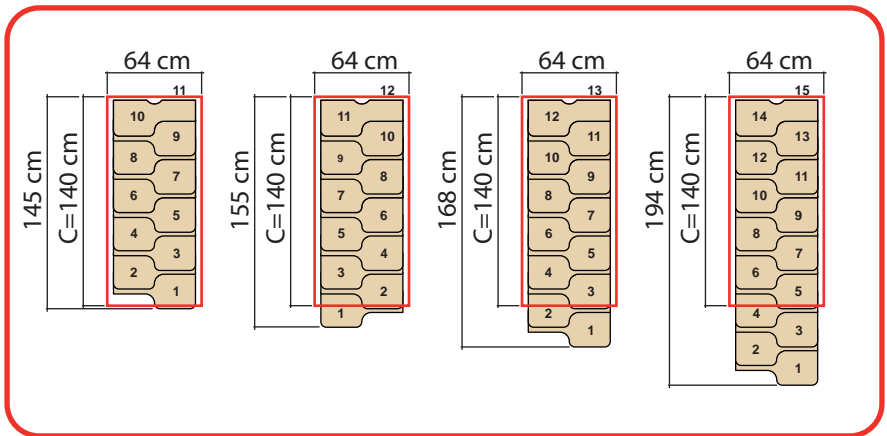

6 b

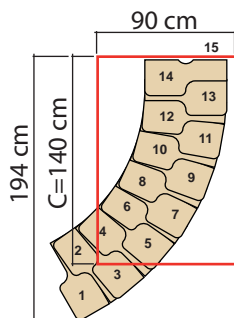
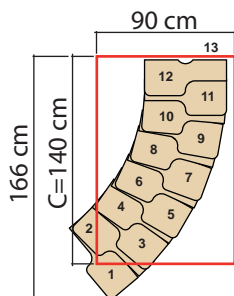
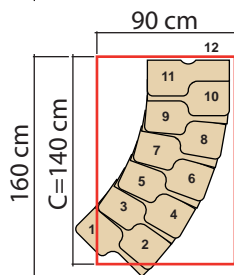
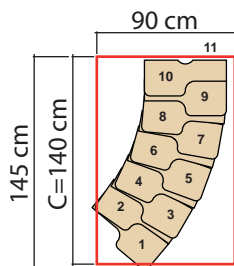
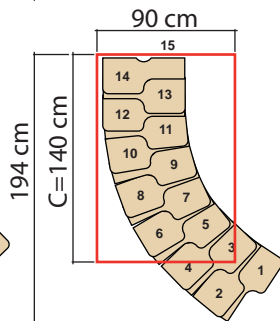
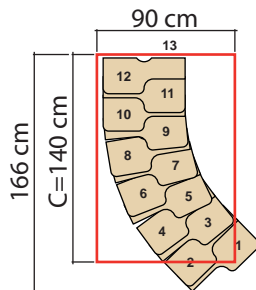
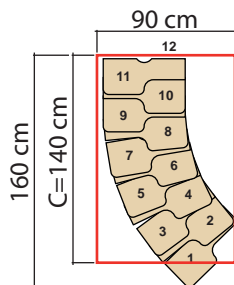
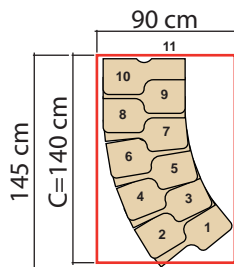
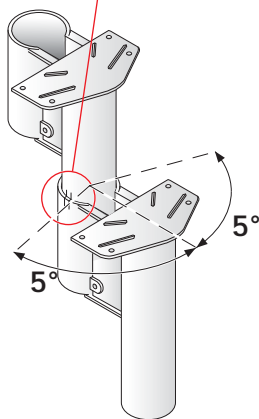
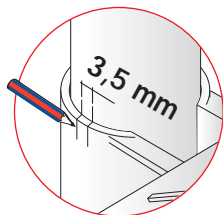

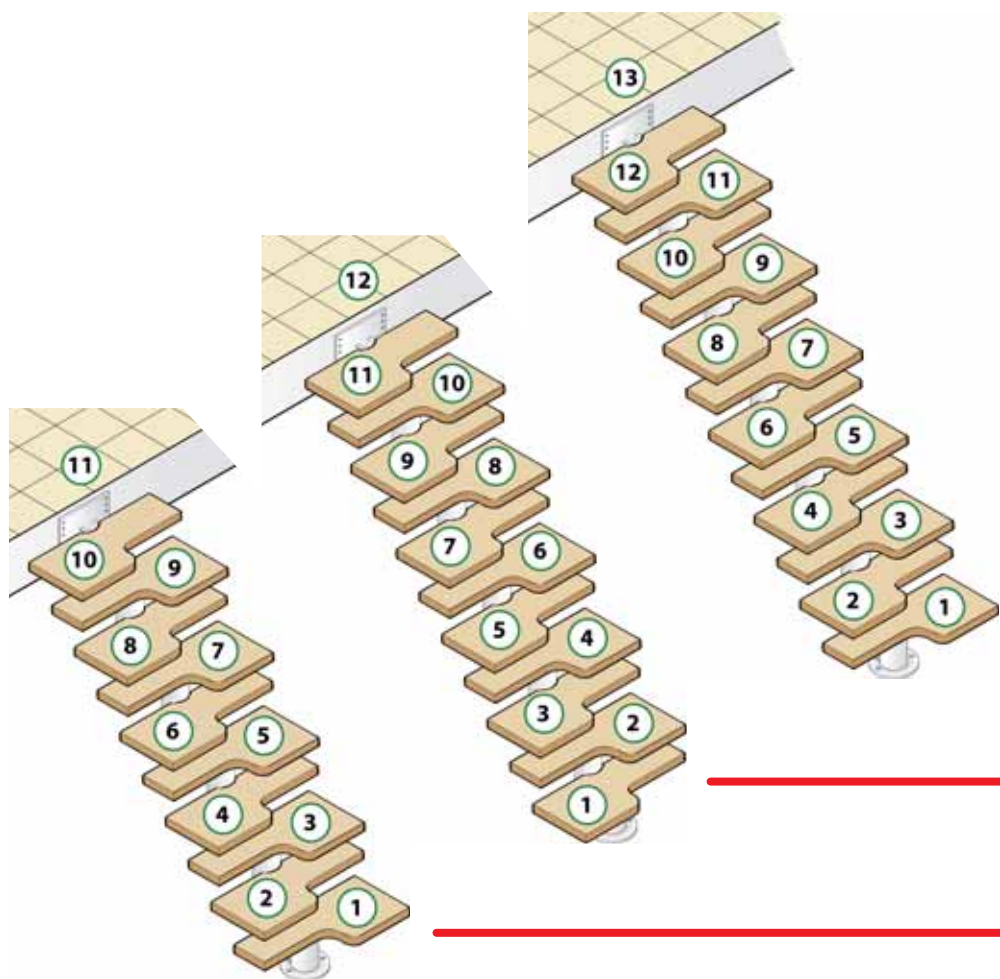

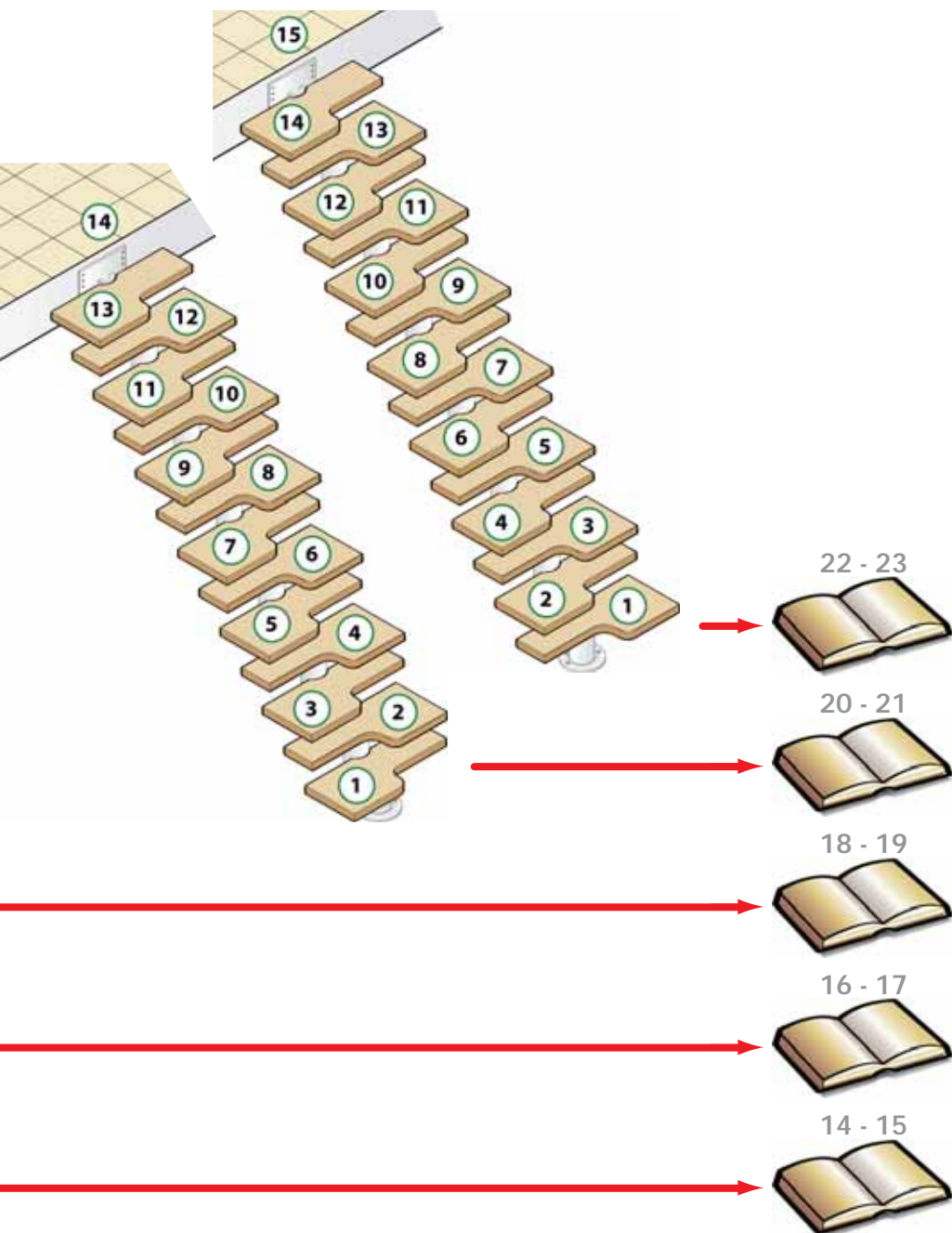

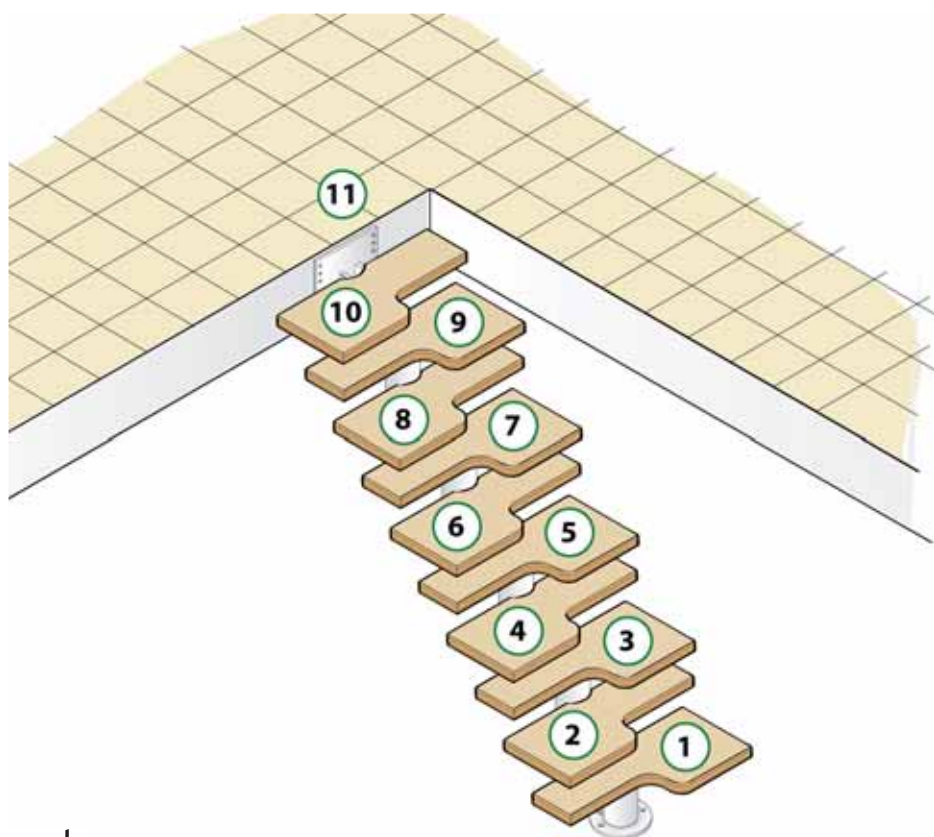
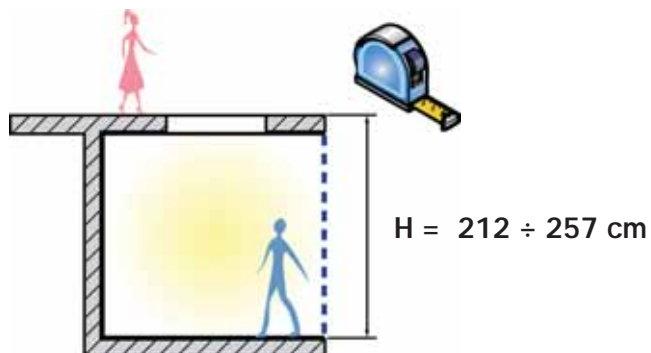

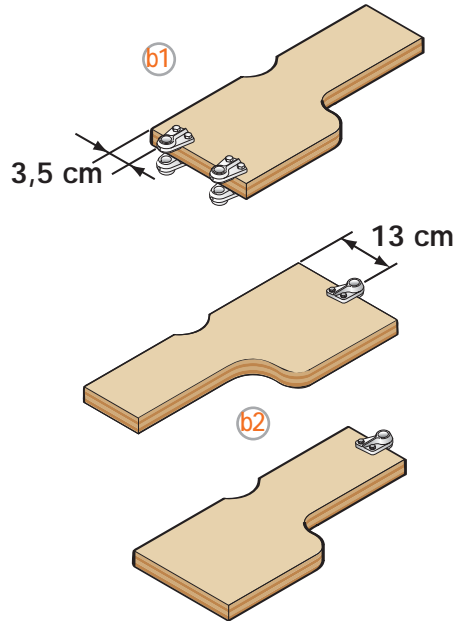
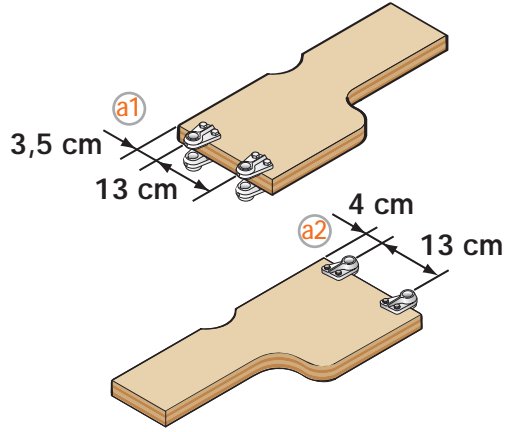
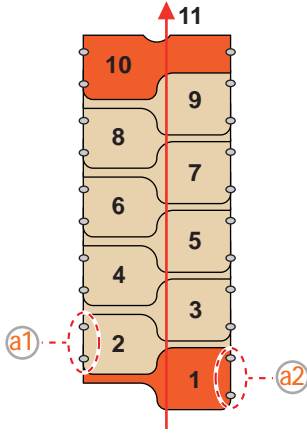

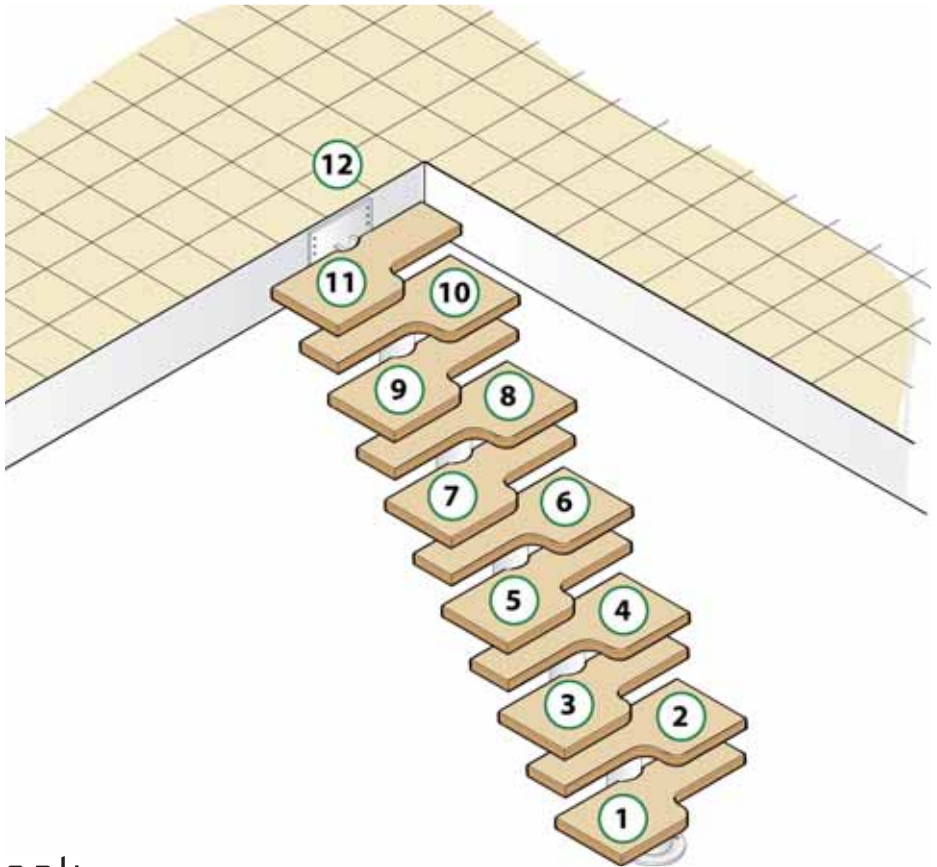
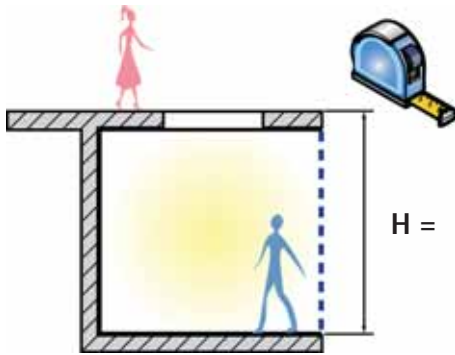

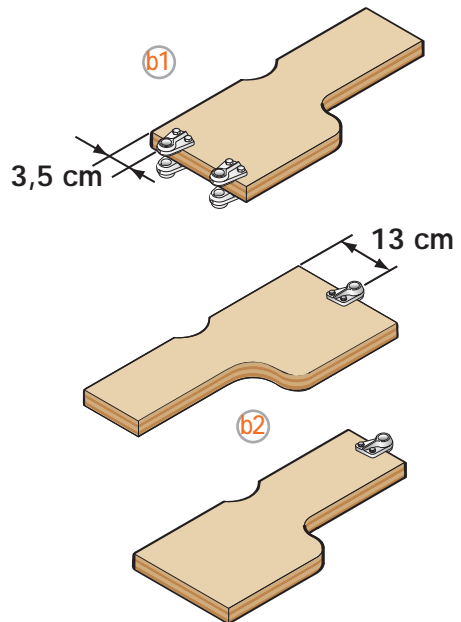
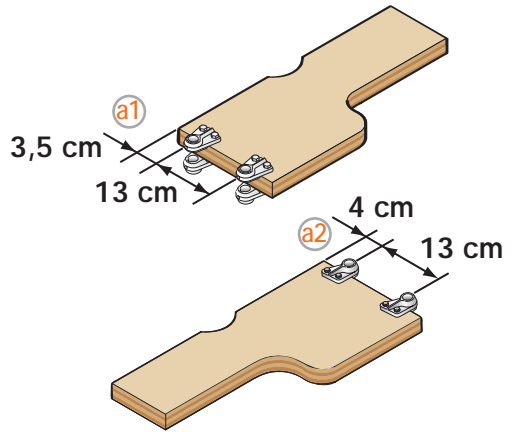
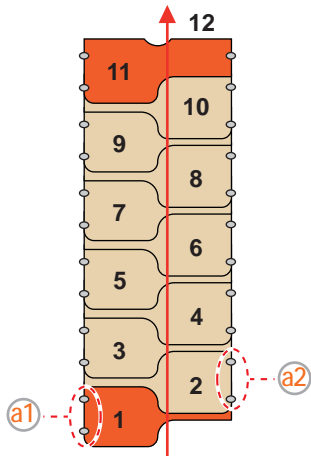

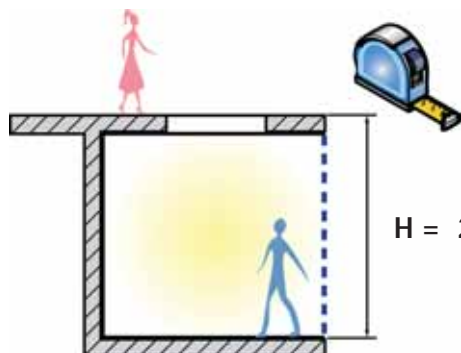

$H = 250 \div 304 \text{ cm}$

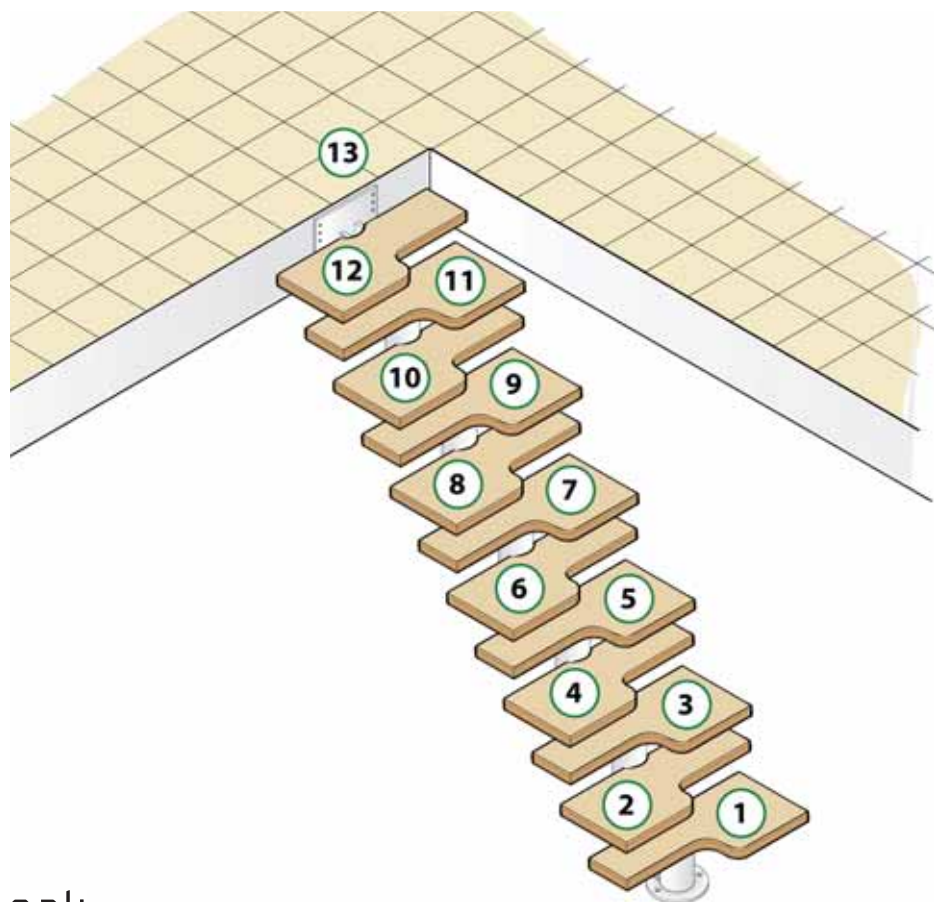

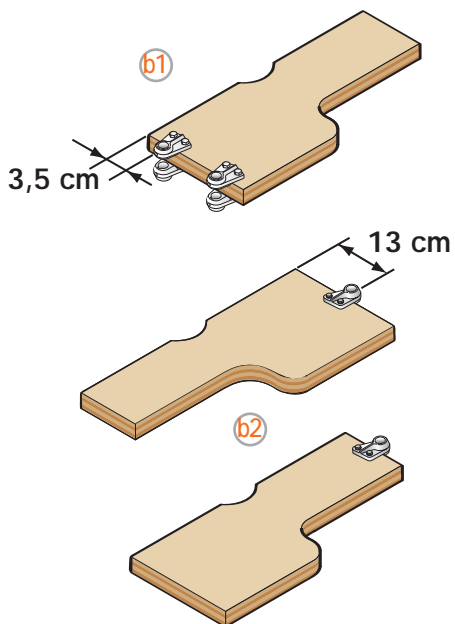
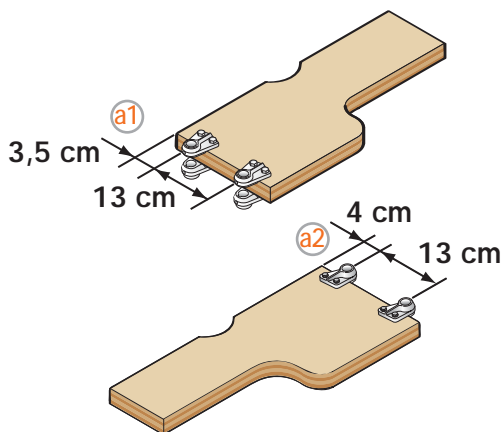
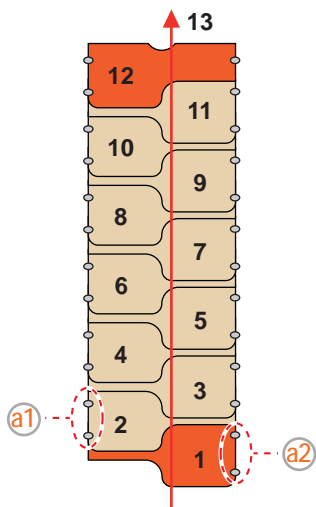

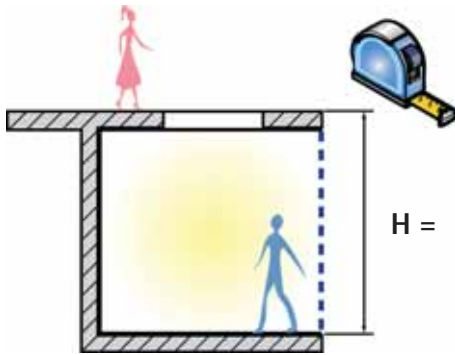

H = 269 ÷ 327 cm

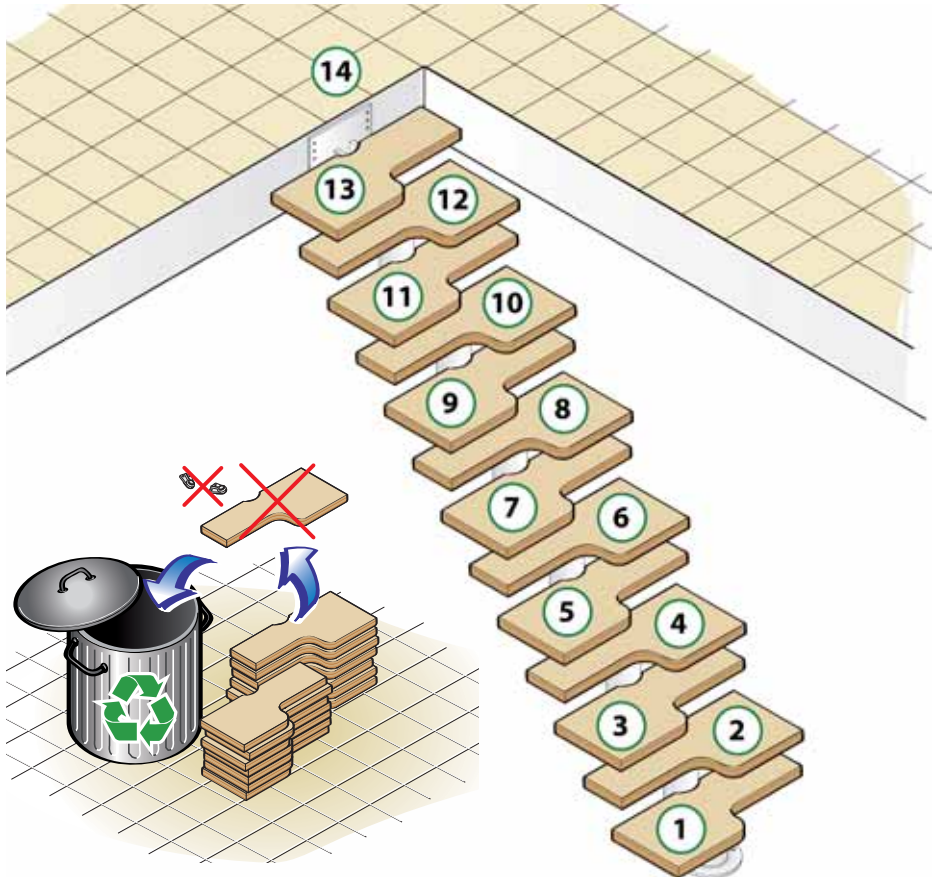

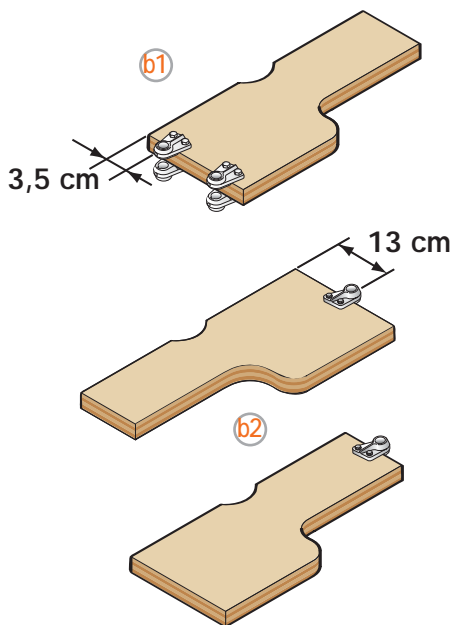
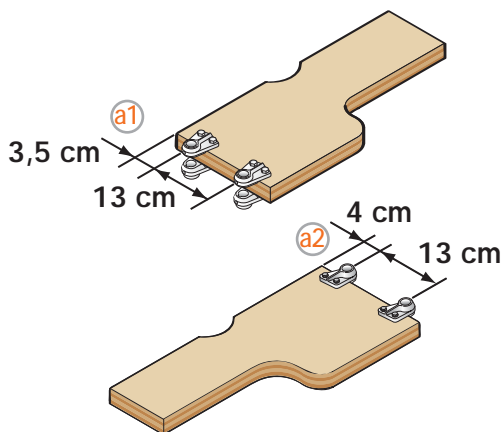
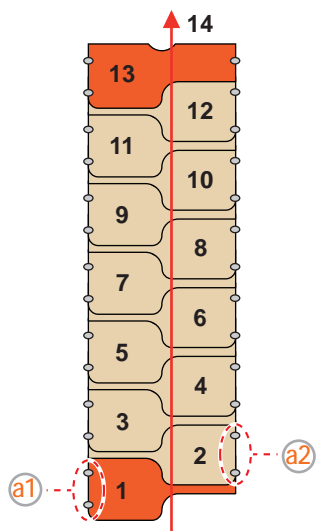

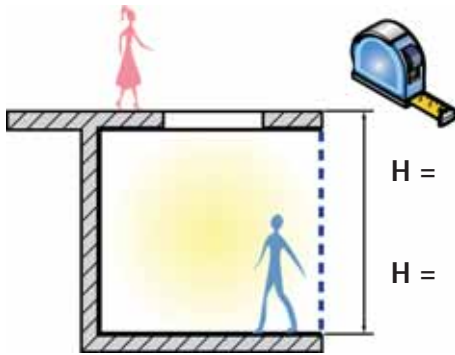

$$H = 269 \div 327 \text{ cm} \quad (14)$$

$$H = 288 \div 351 \text{ cm} \quad (15)$$

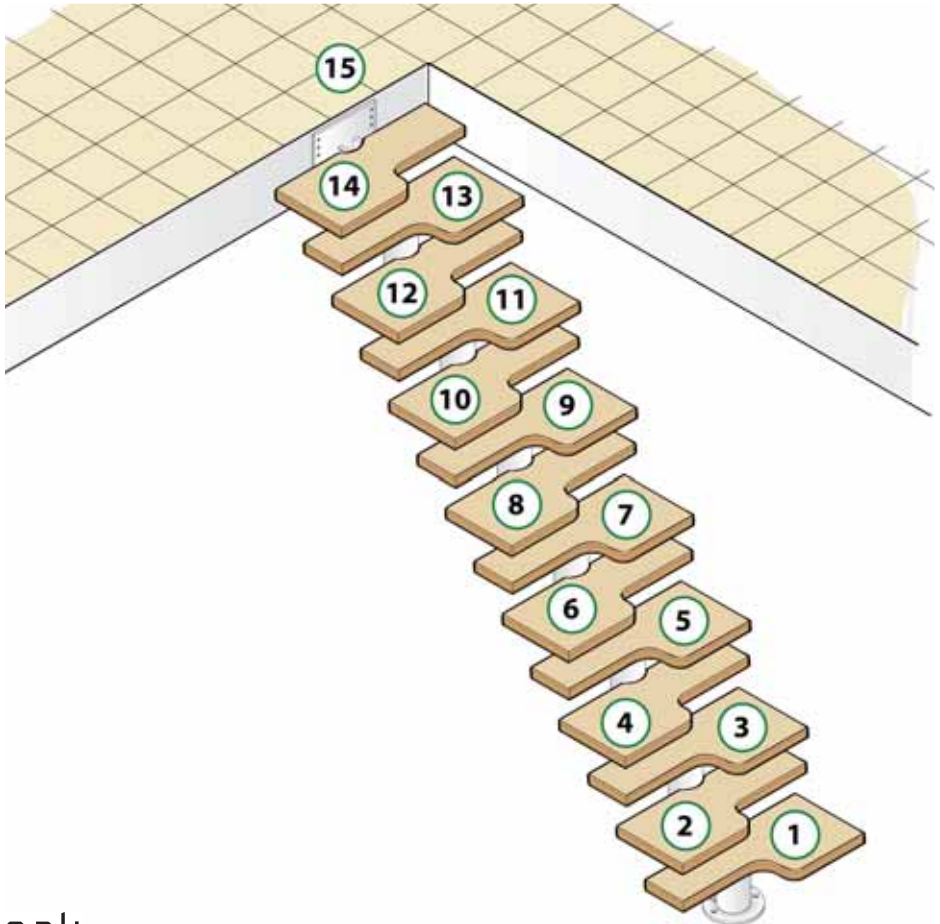

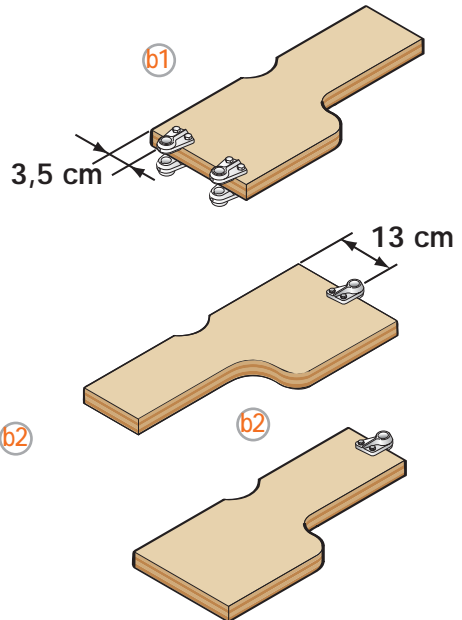
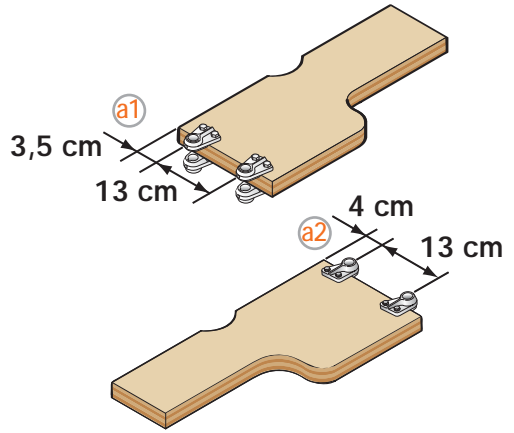
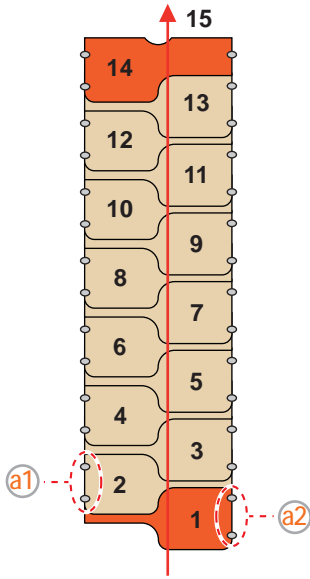

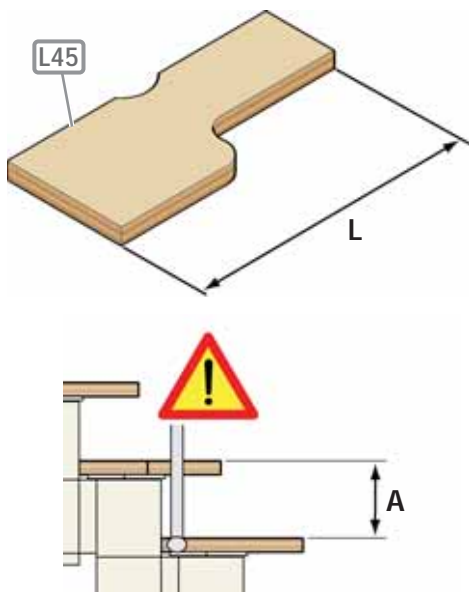
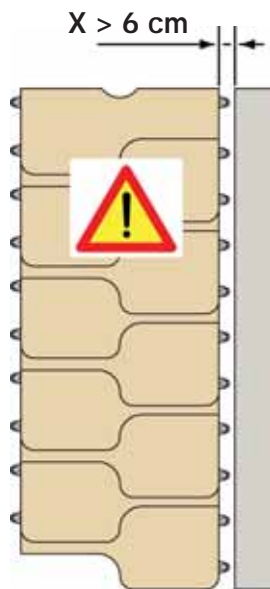
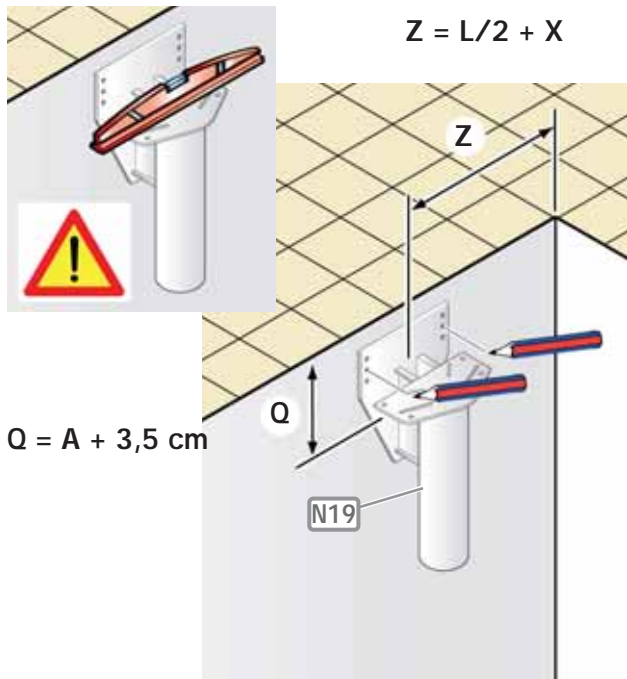

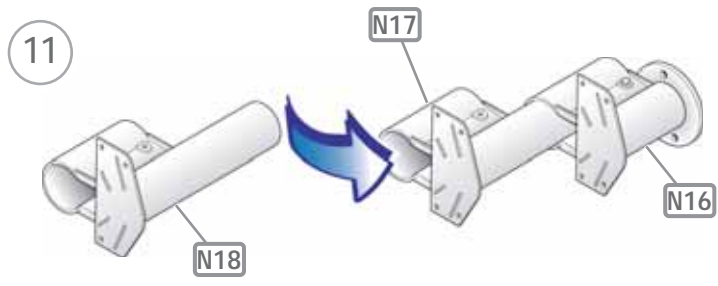
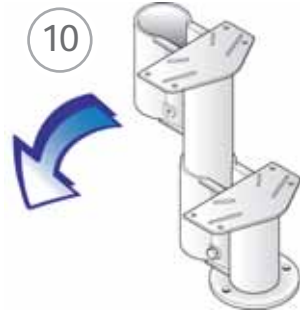
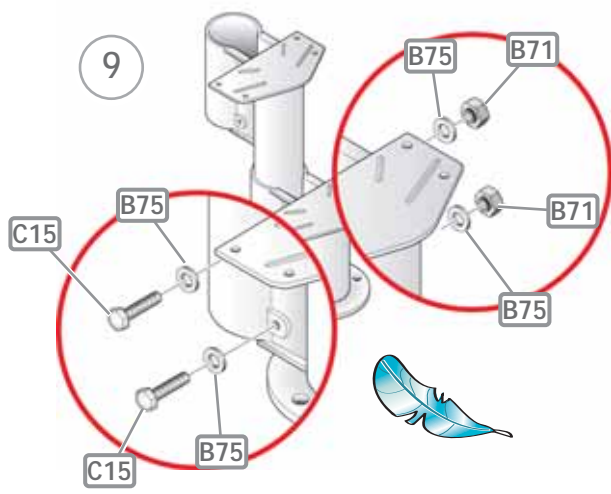
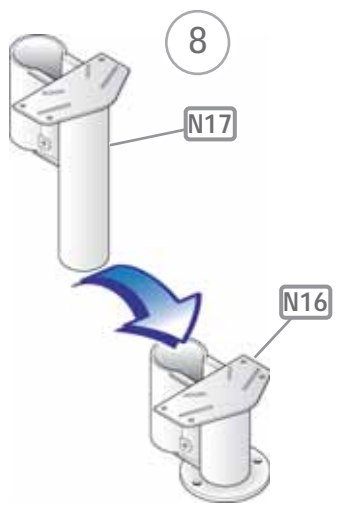
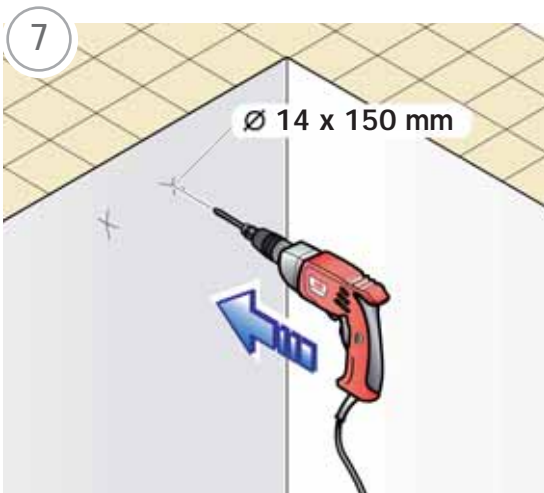

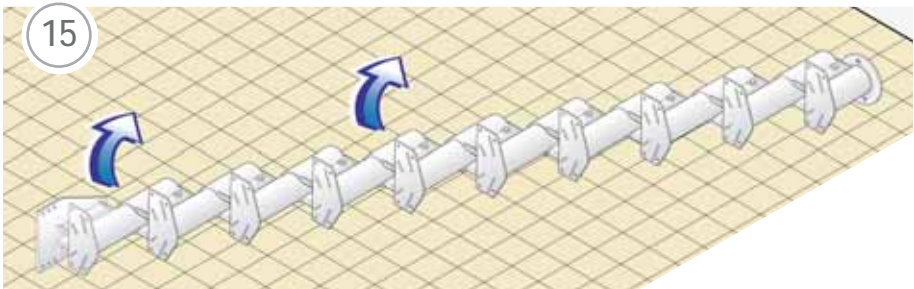
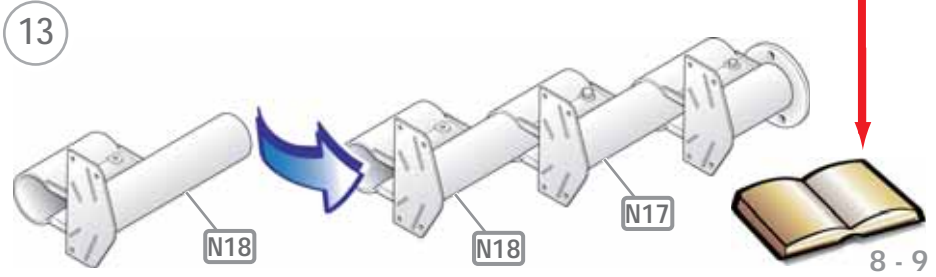
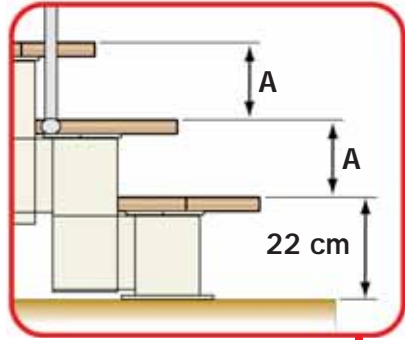
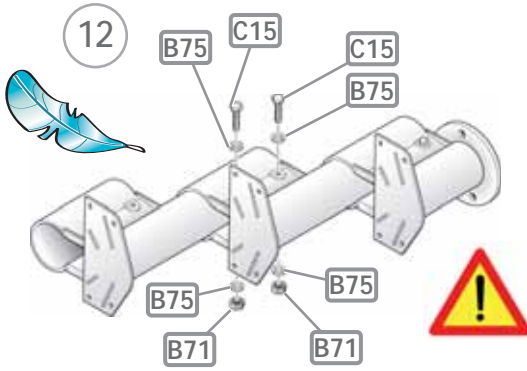

16

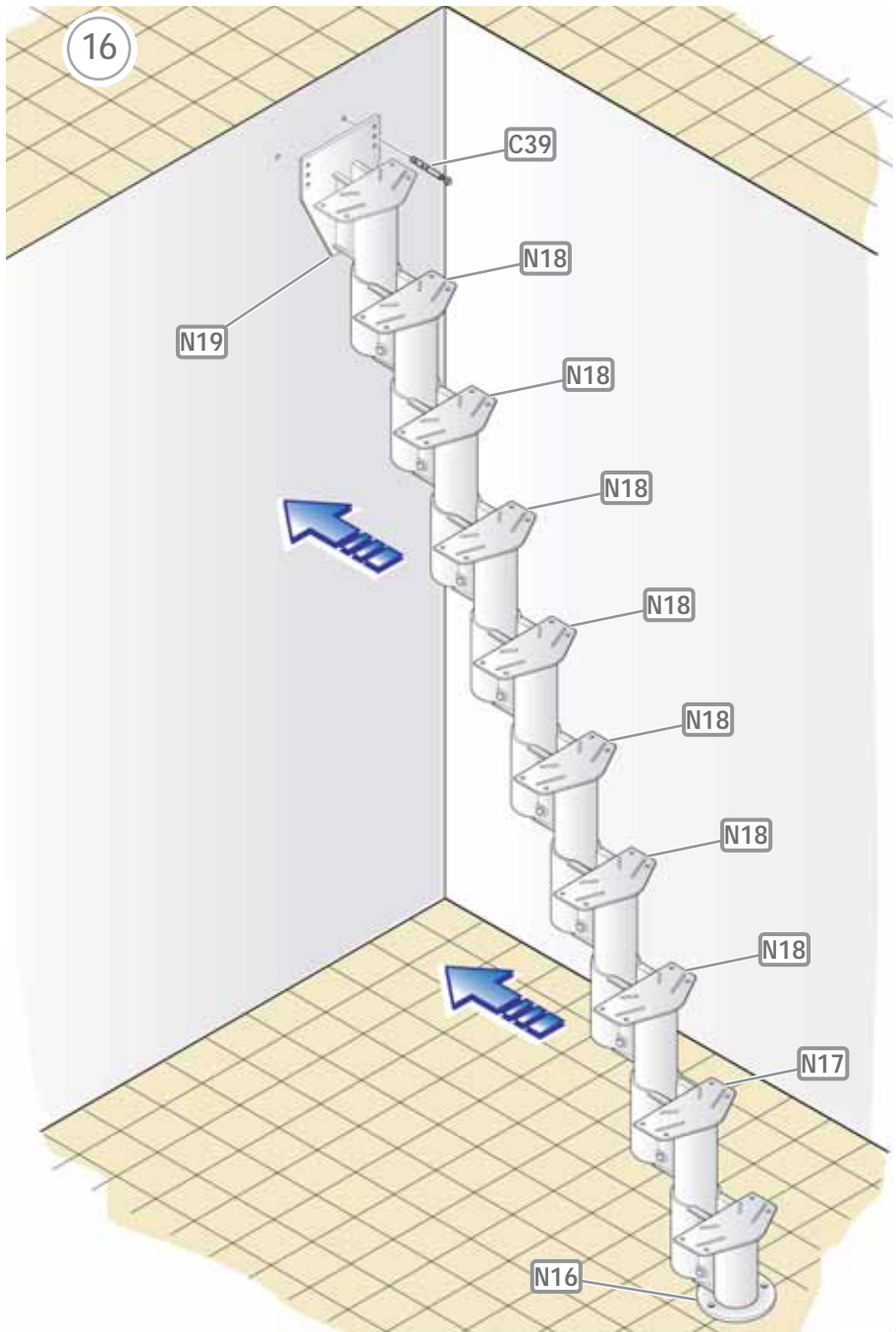

17

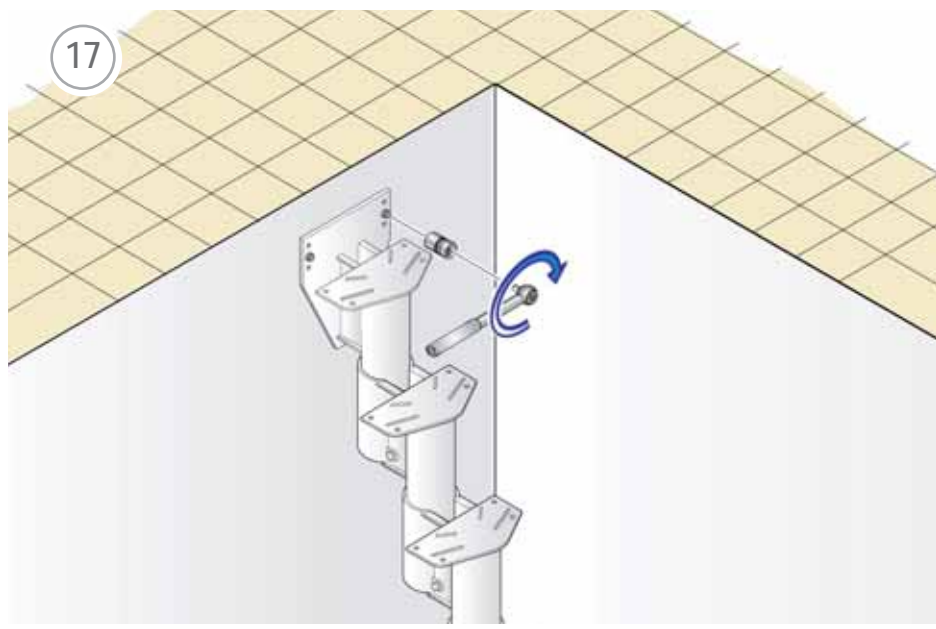

18

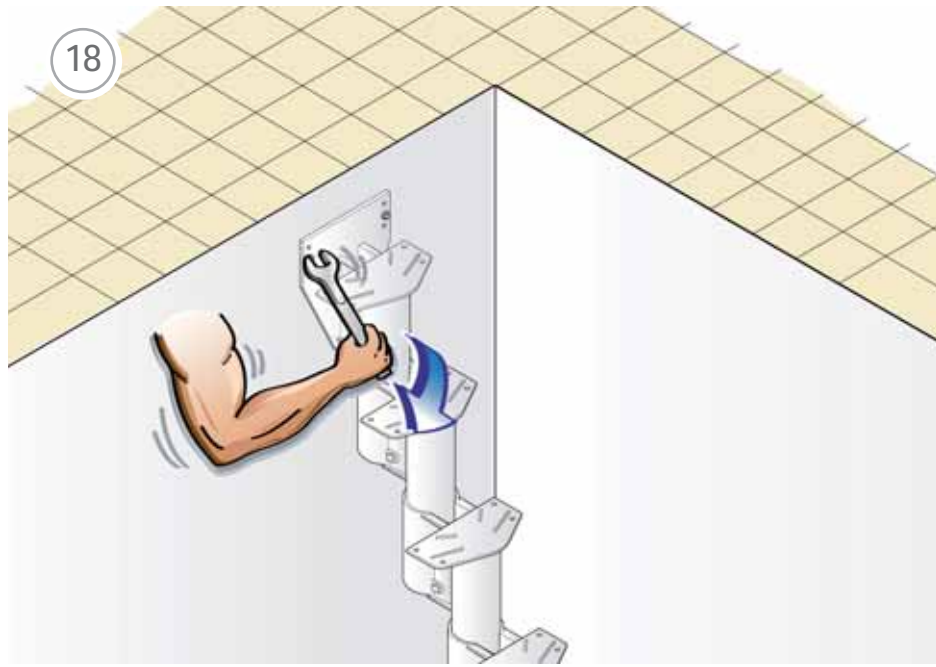

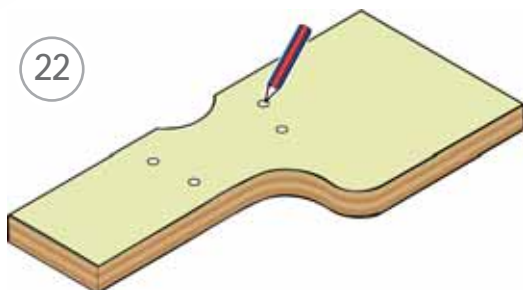
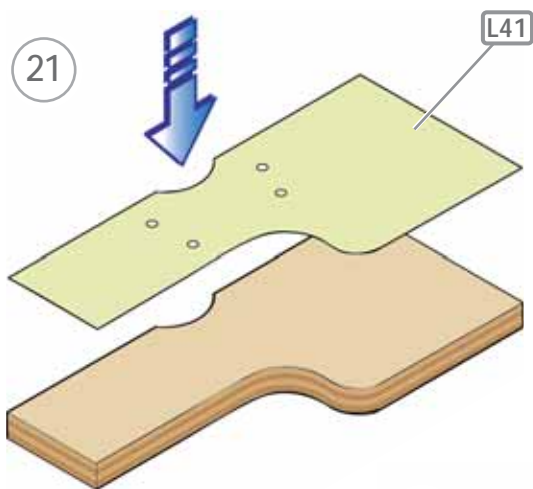
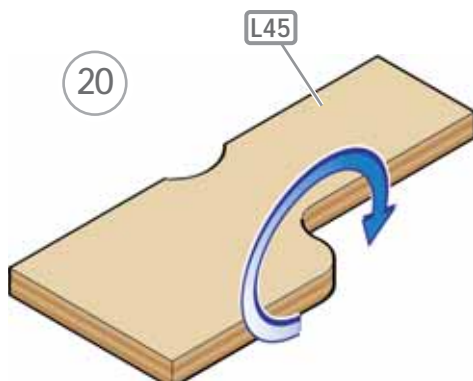
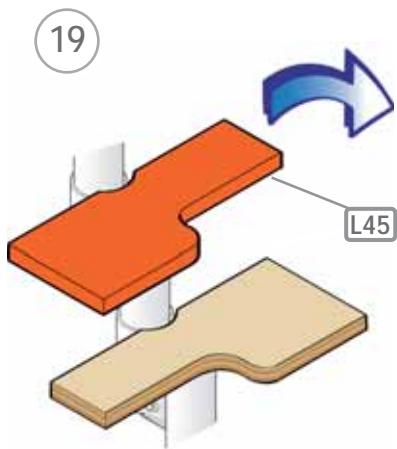

23

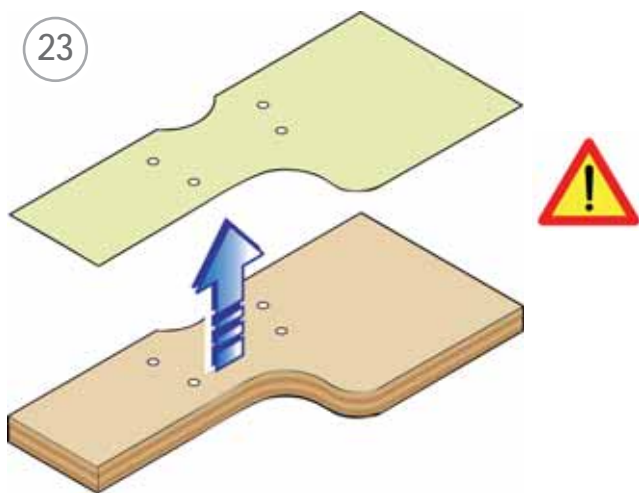

24

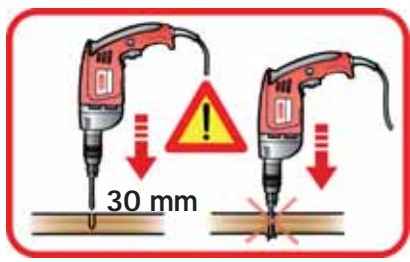
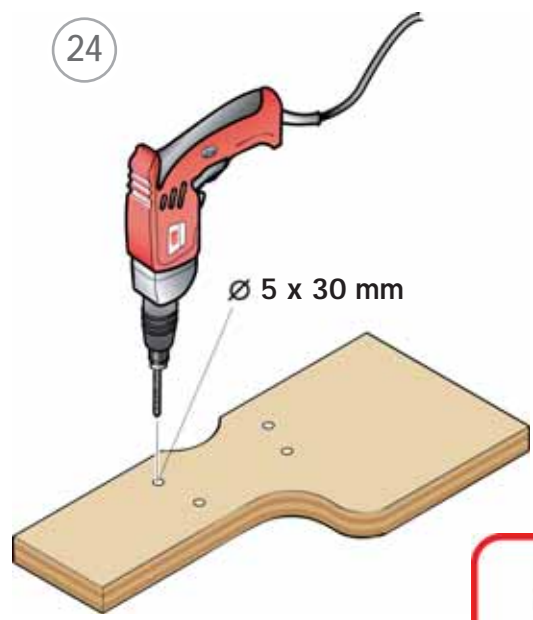

25

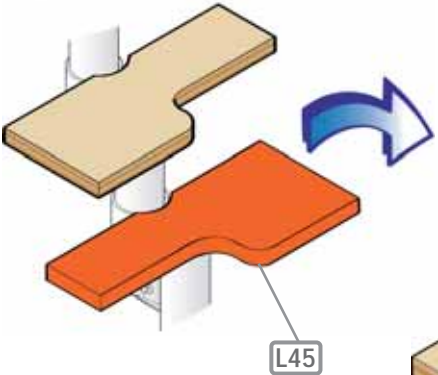

26

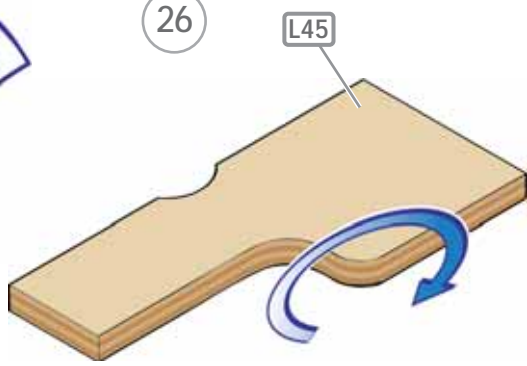

27

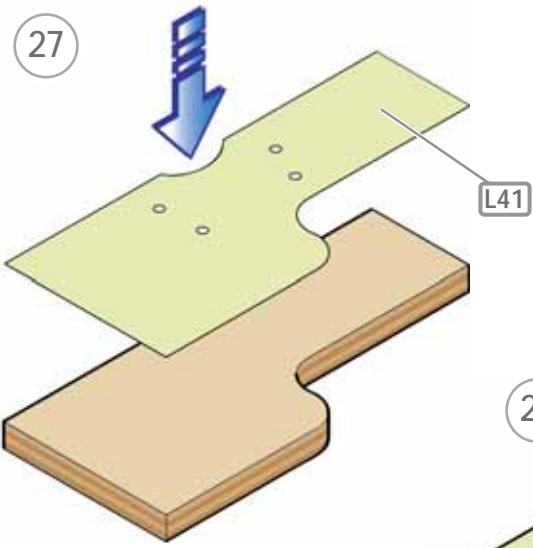

28

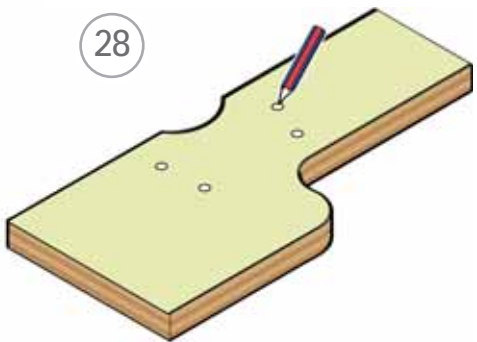

29

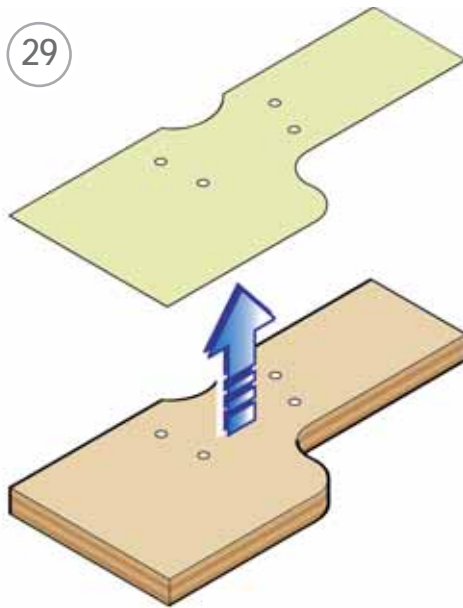

30

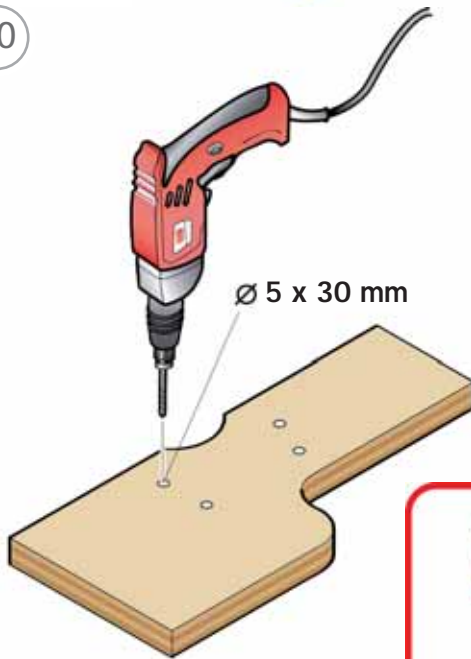

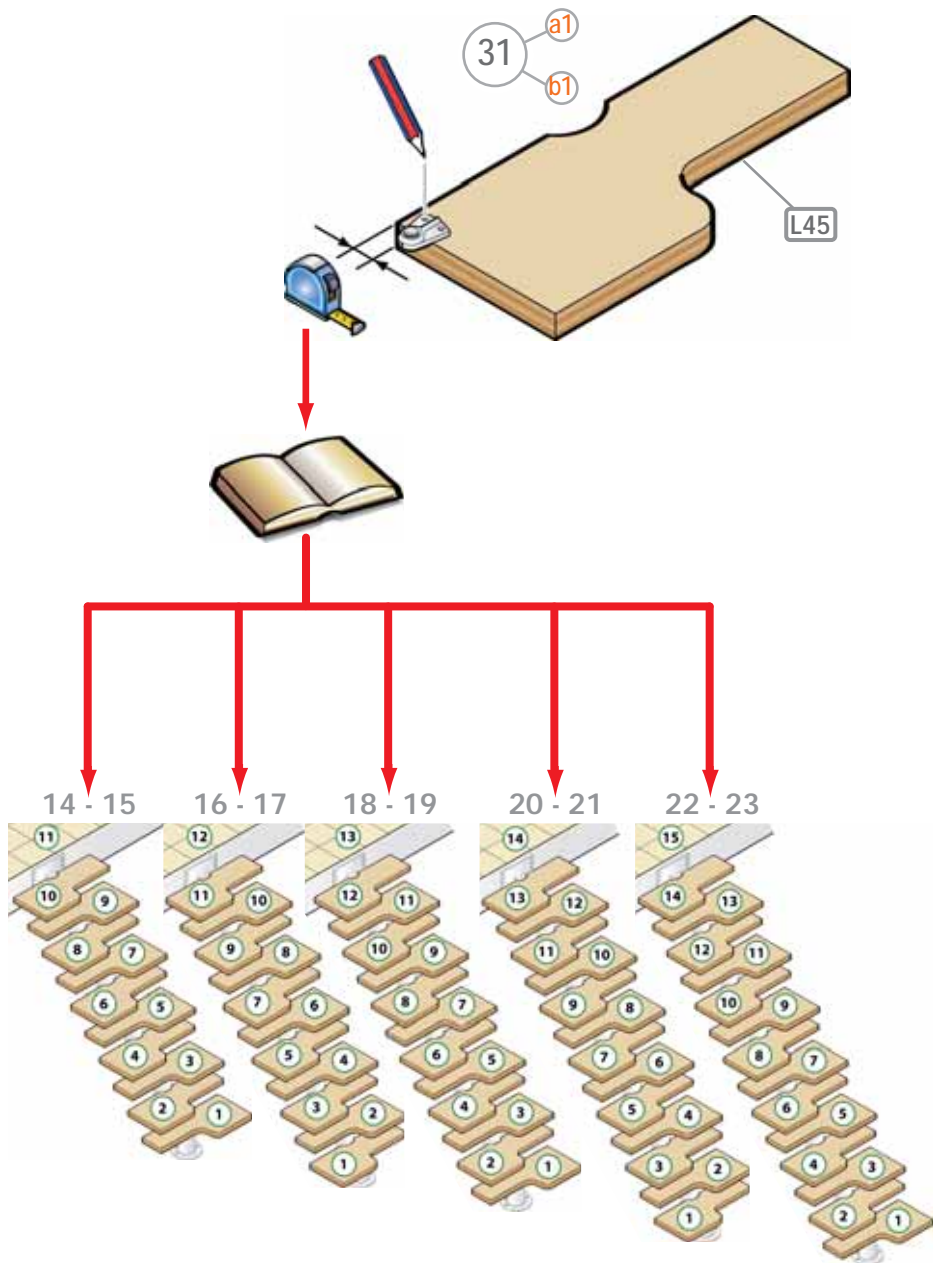

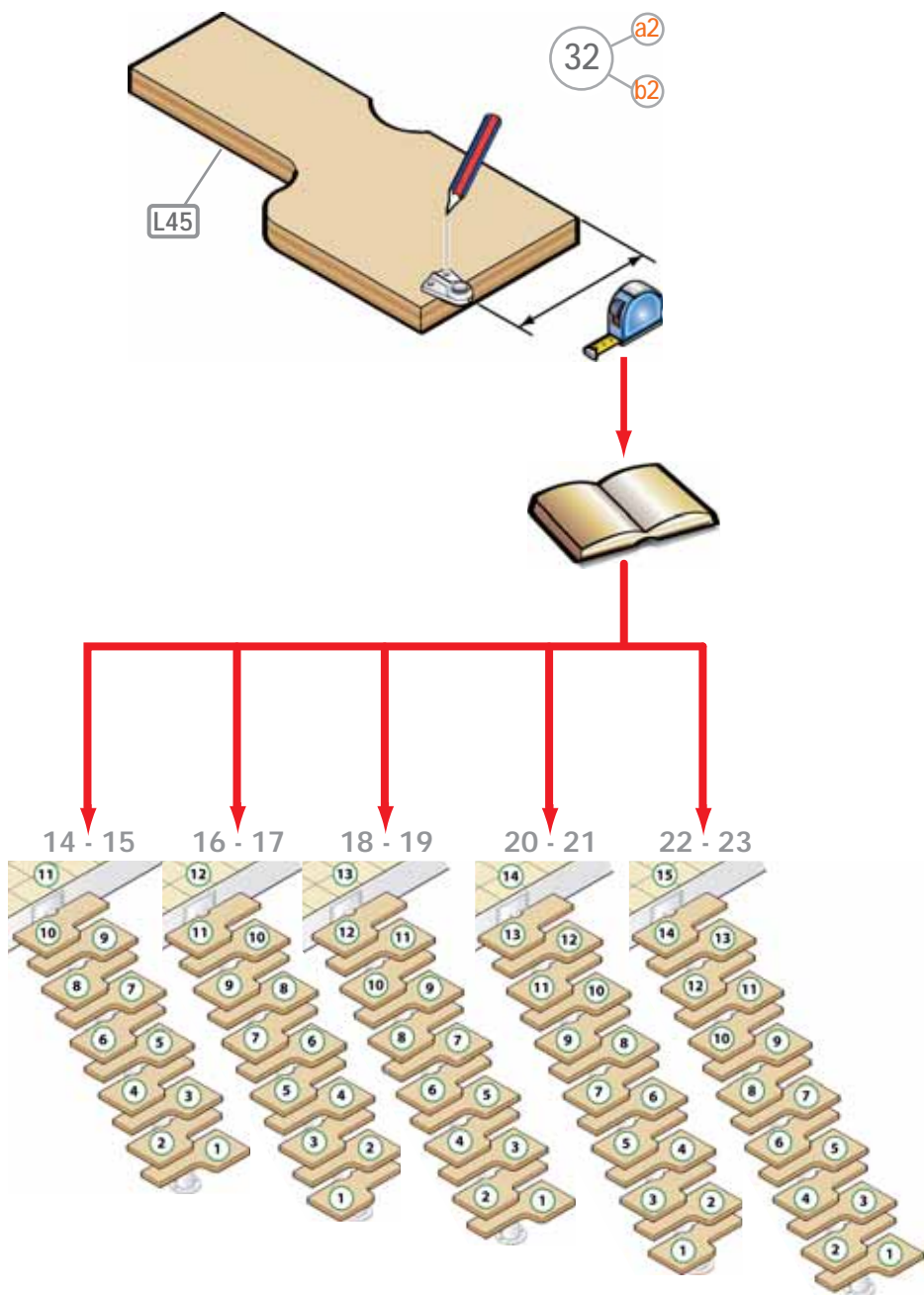

33

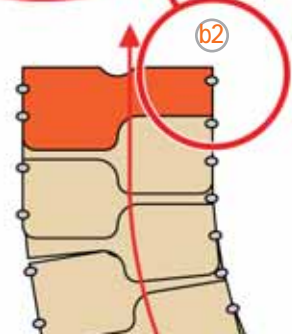
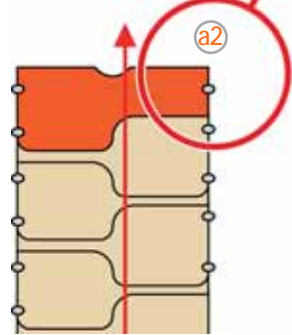
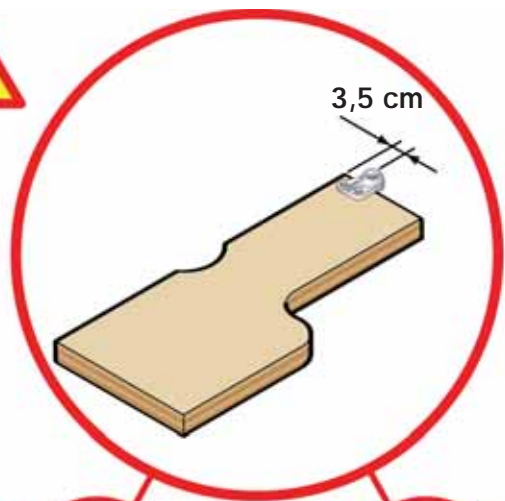

34

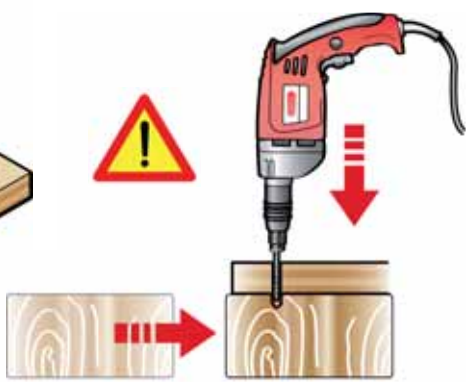
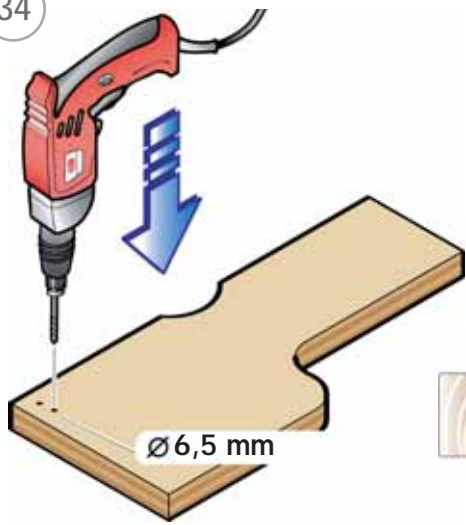

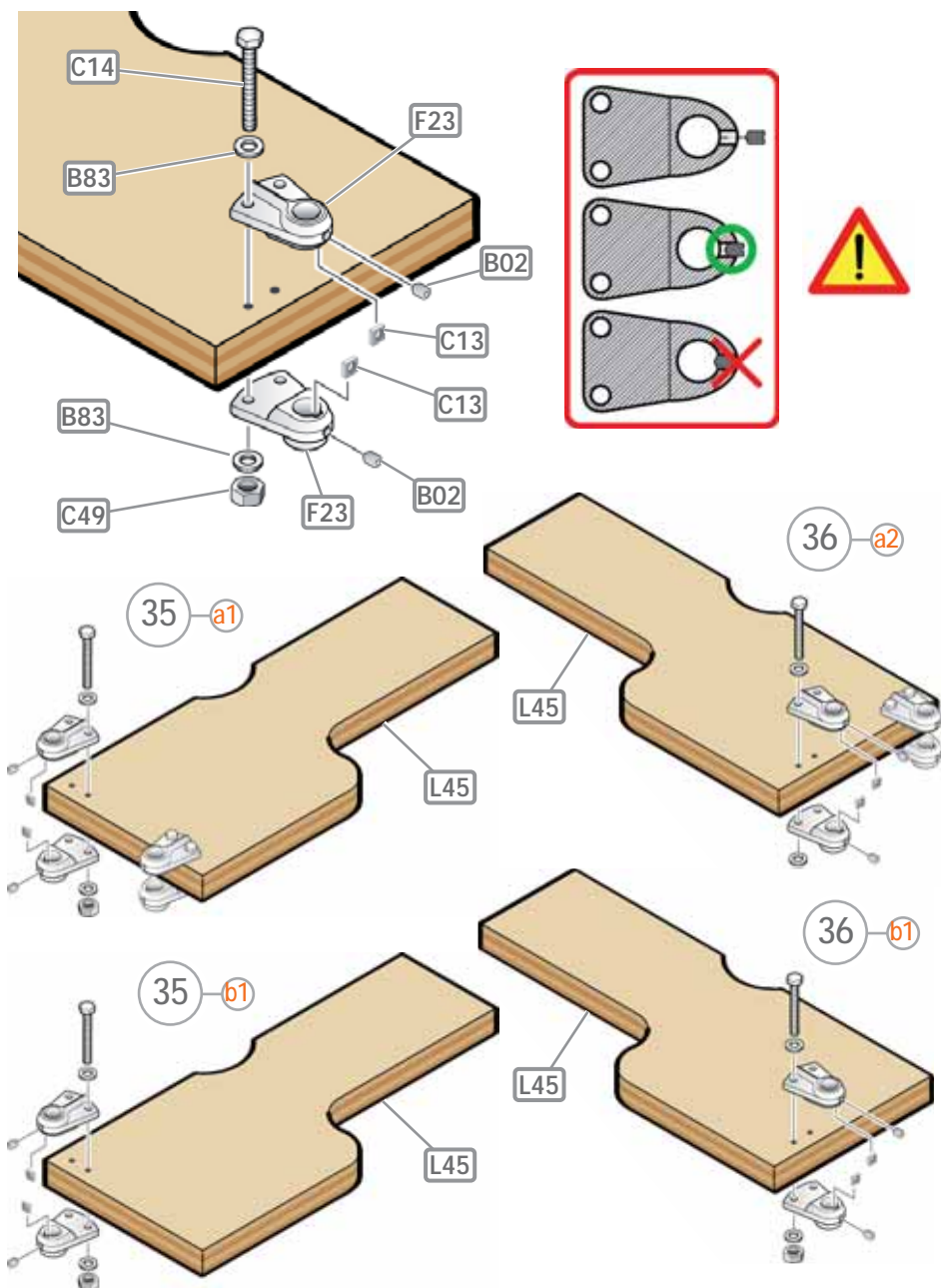

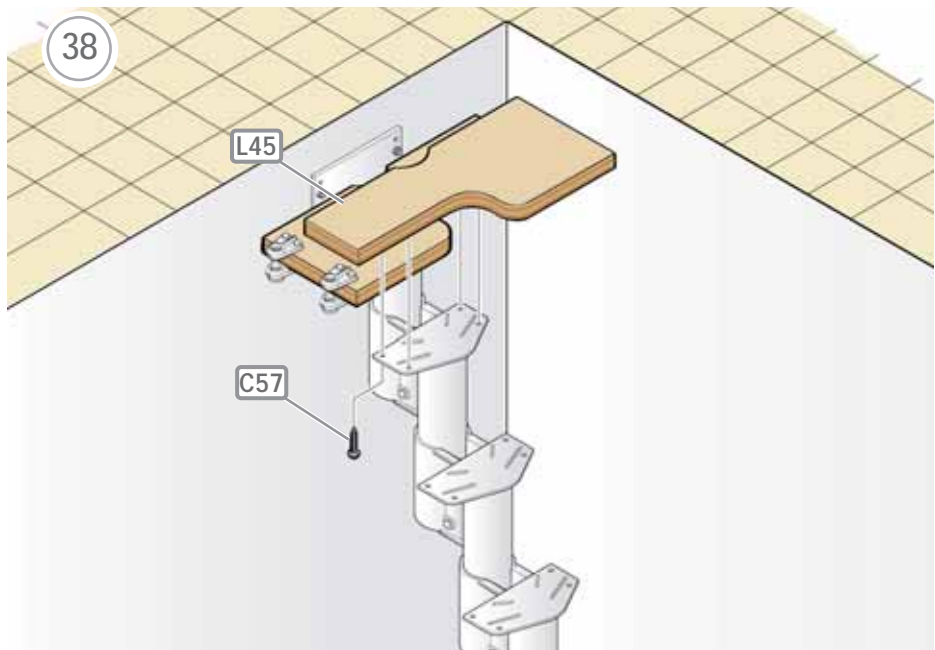
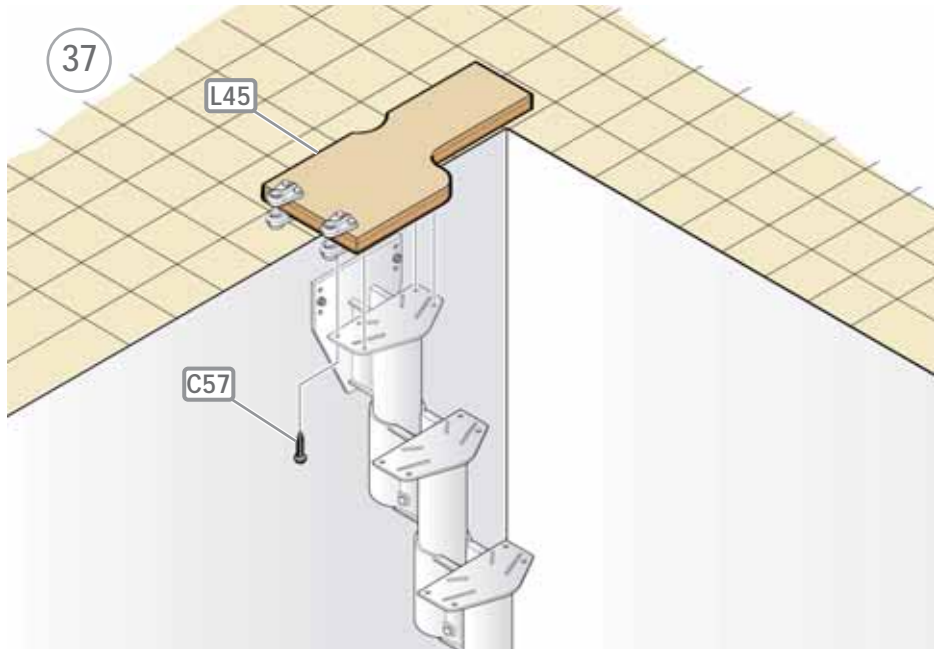

a1	a2	b1	b2
D = 98 cm 		D = 98 cm 	
	D = 88 cm 		D = 92 cm

39

C03

D

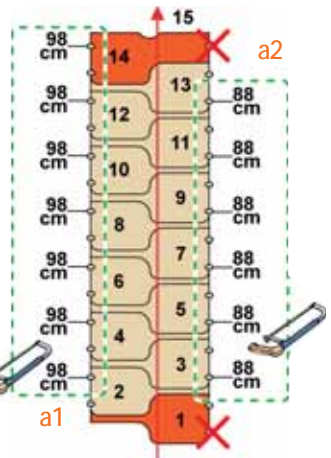
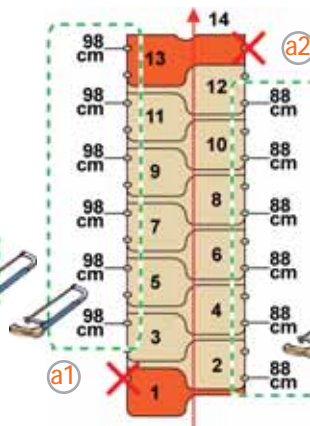
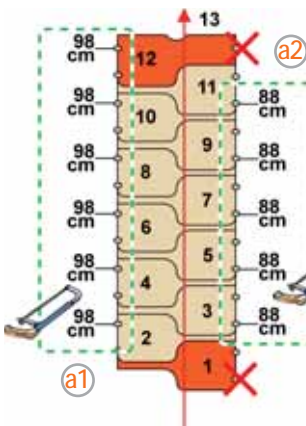
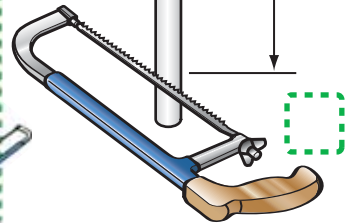
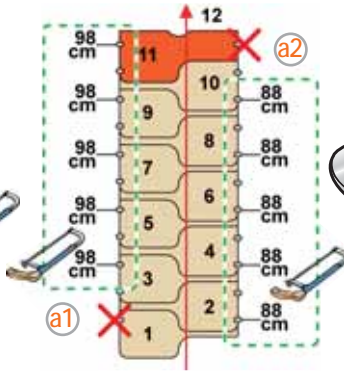
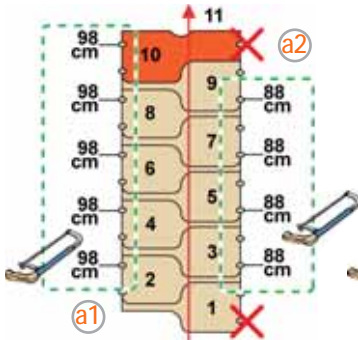

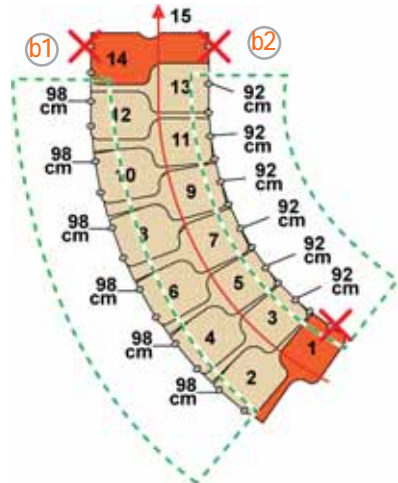
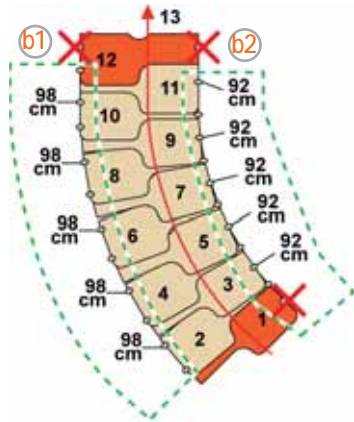
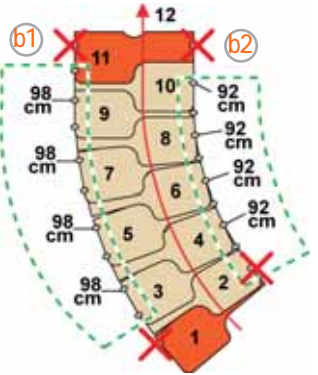
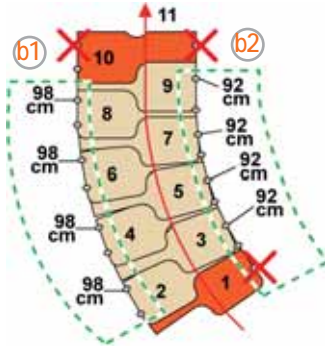
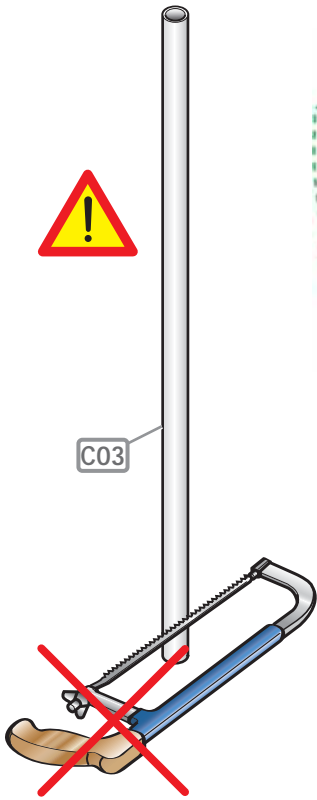

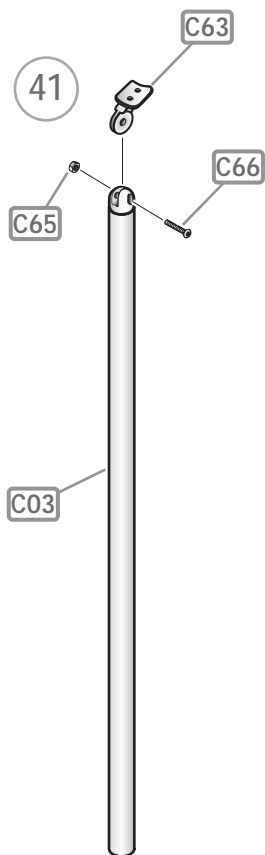
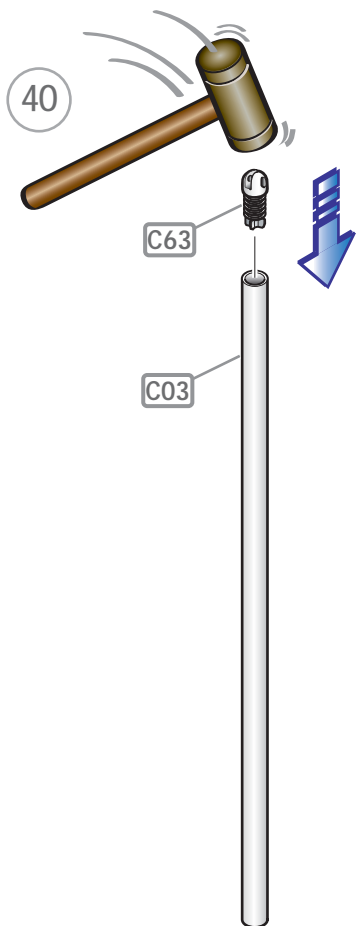

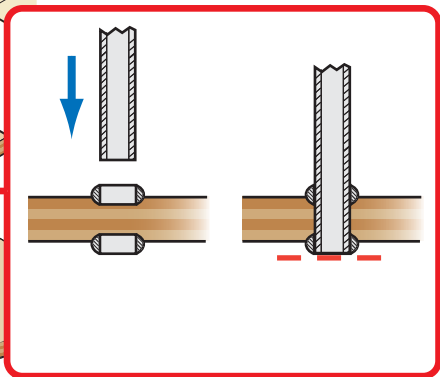
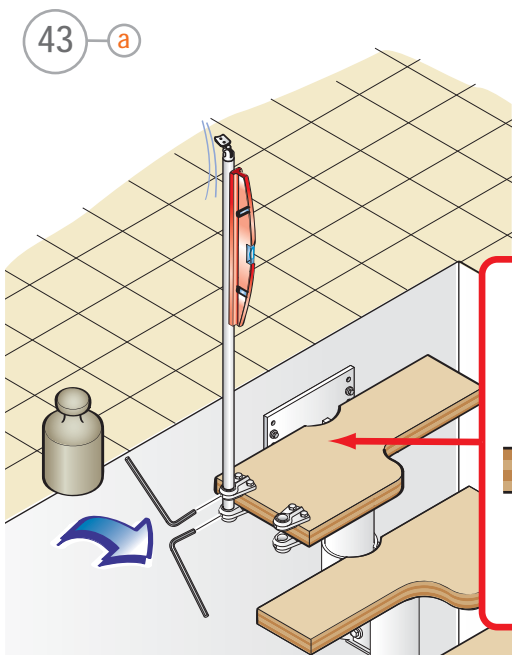
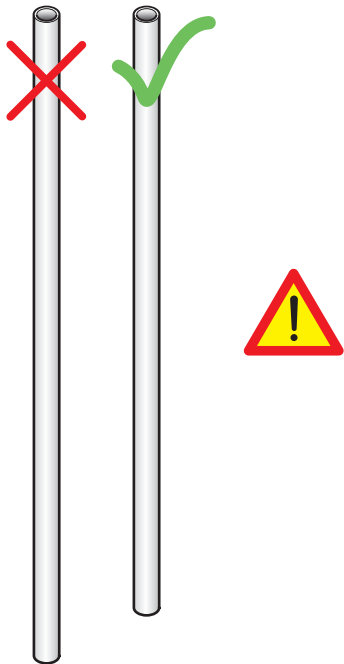
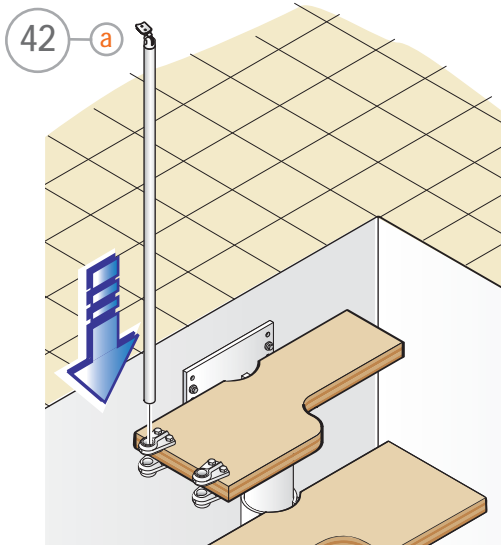

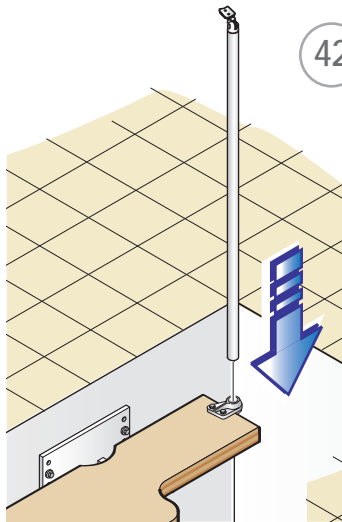
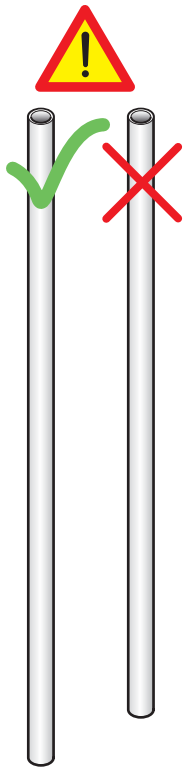

42 b

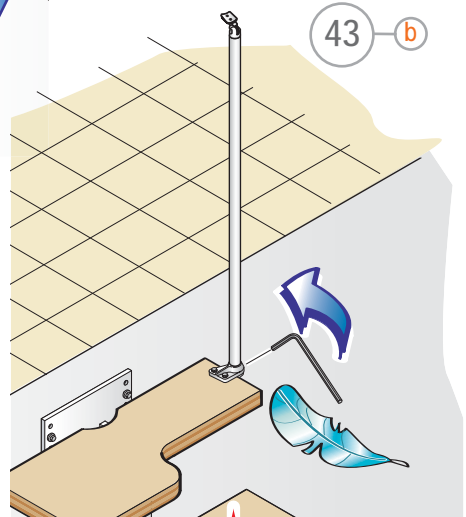

43 b

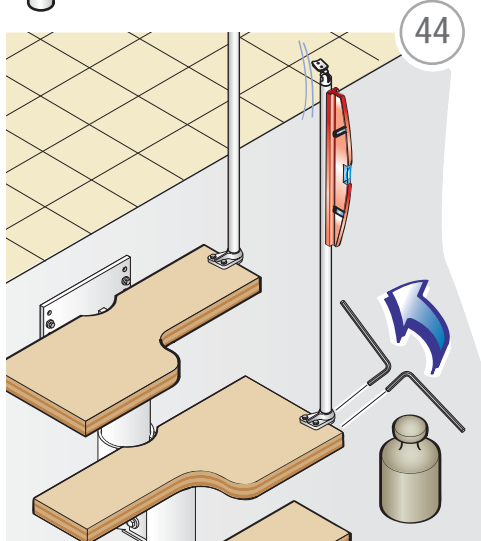

44

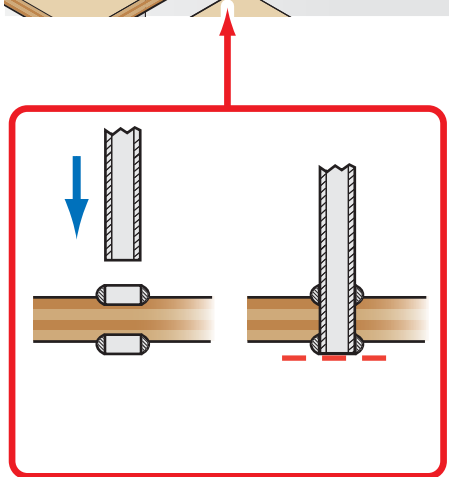

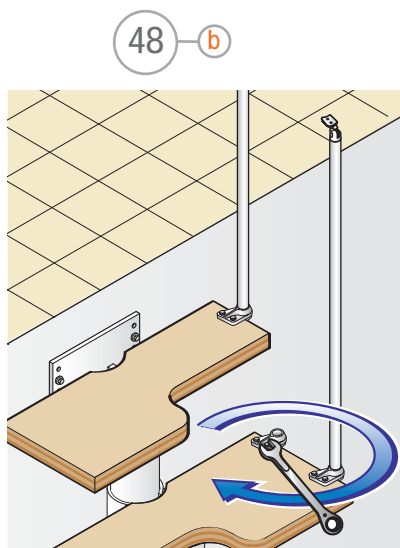
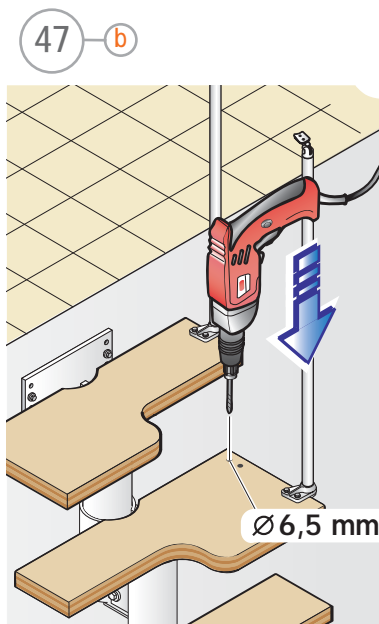
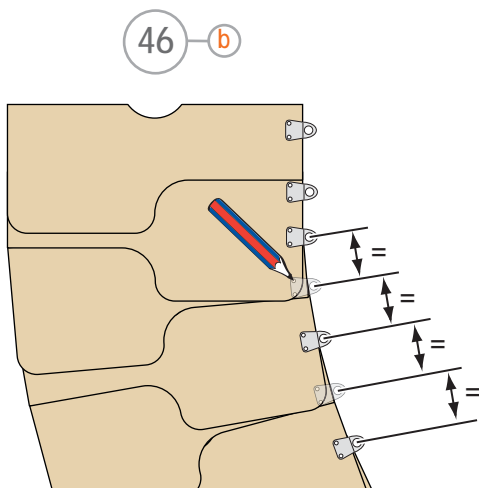
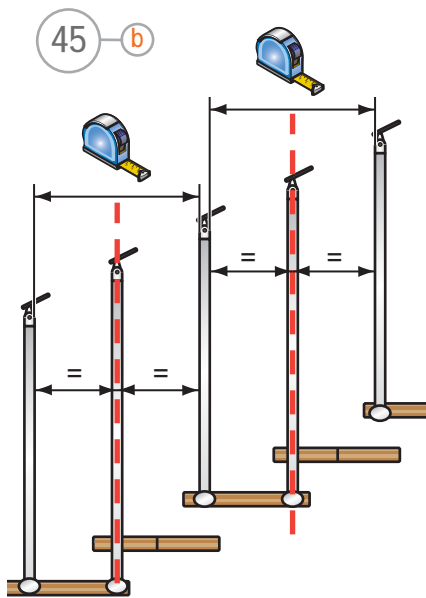

49

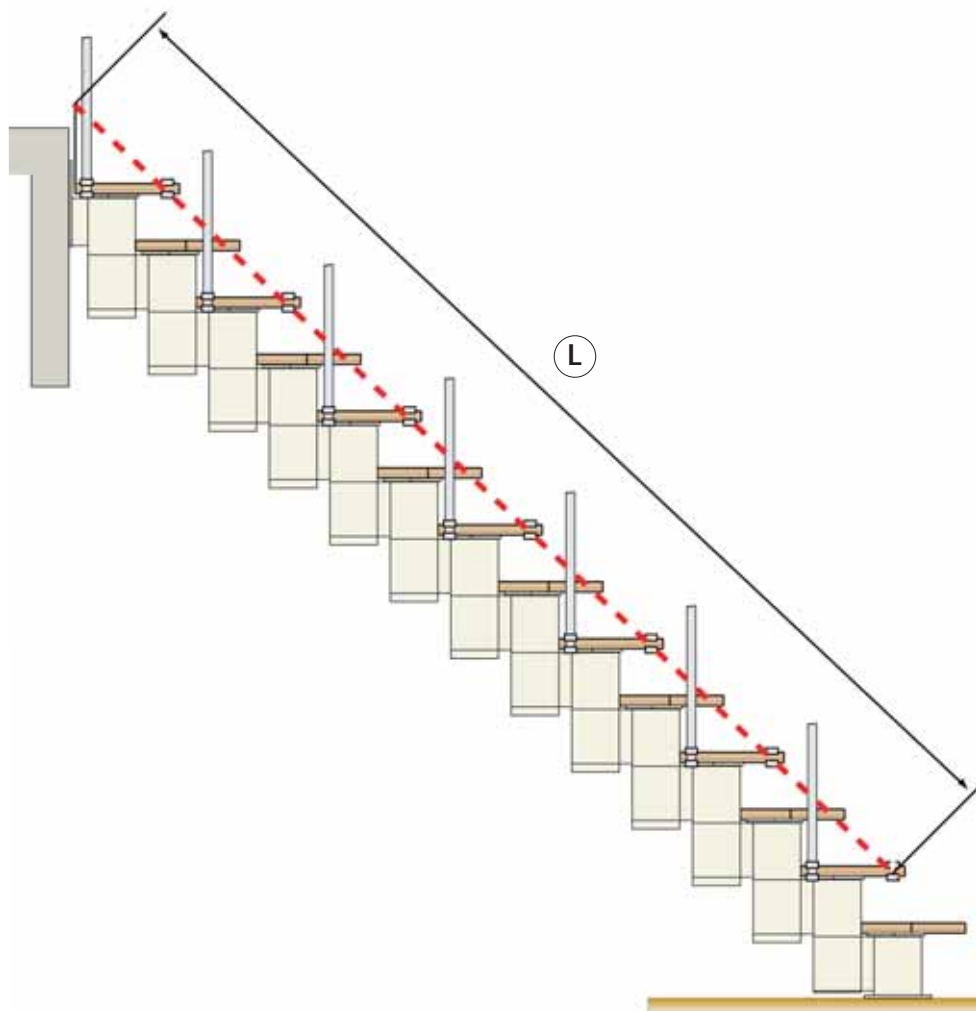

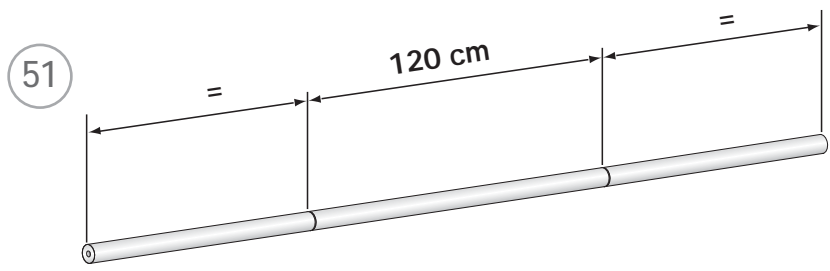
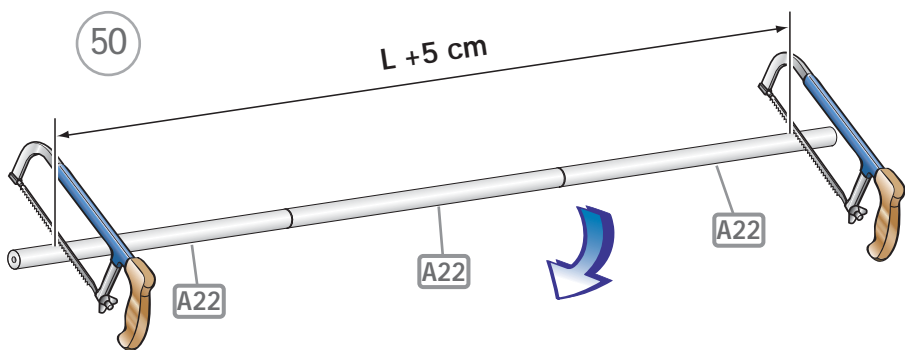
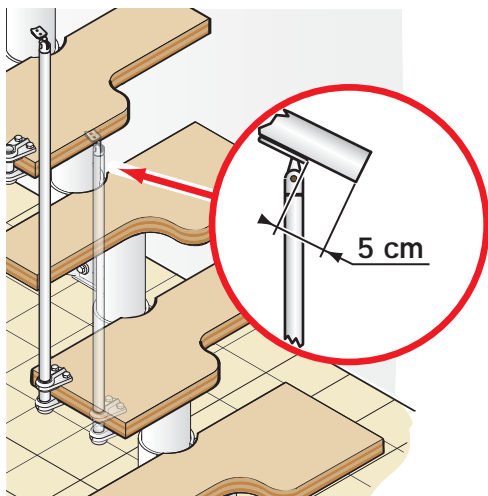

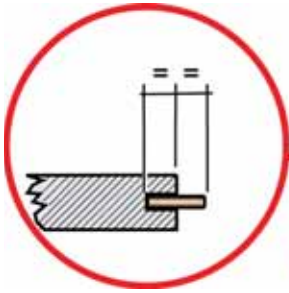

52

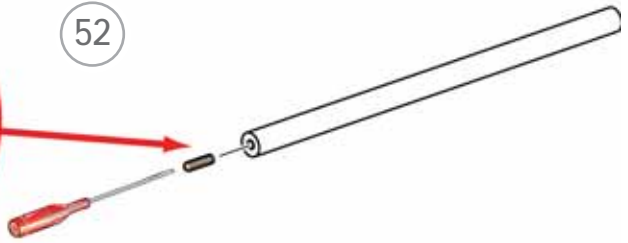

53

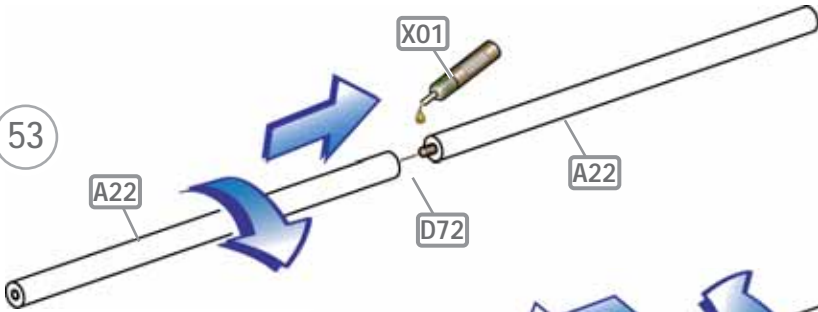

54

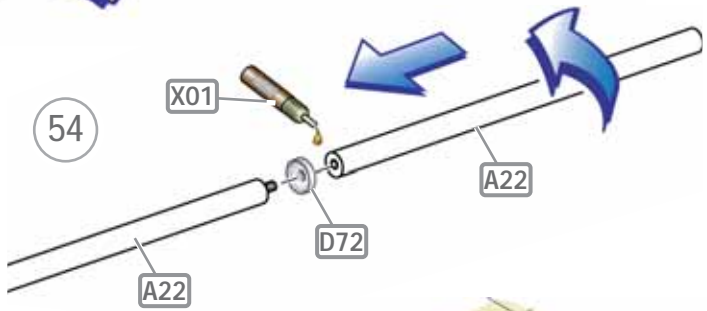

55

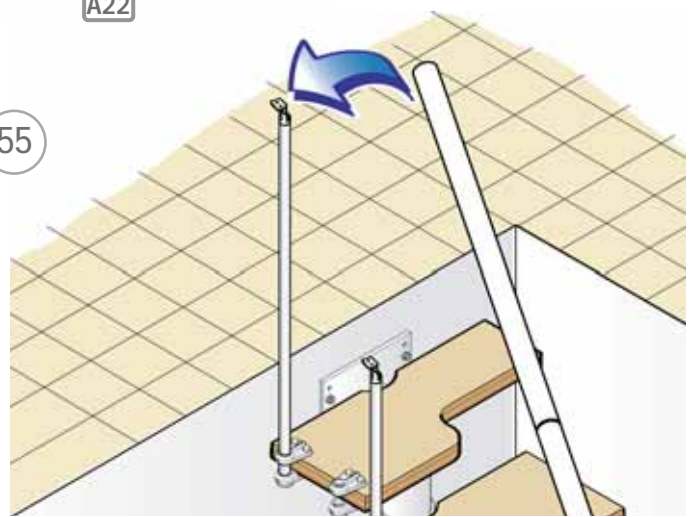

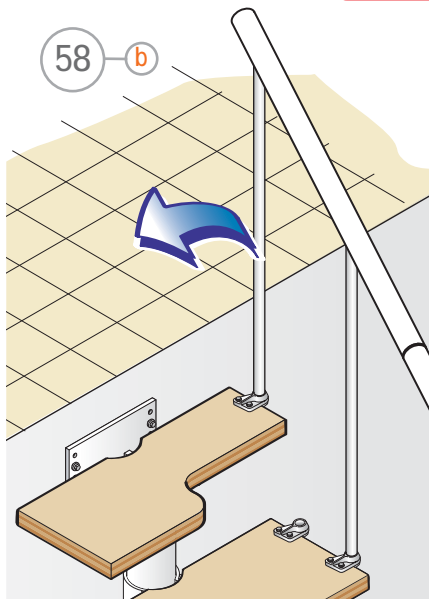
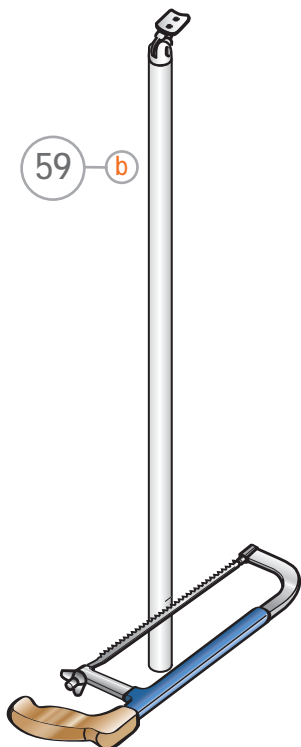
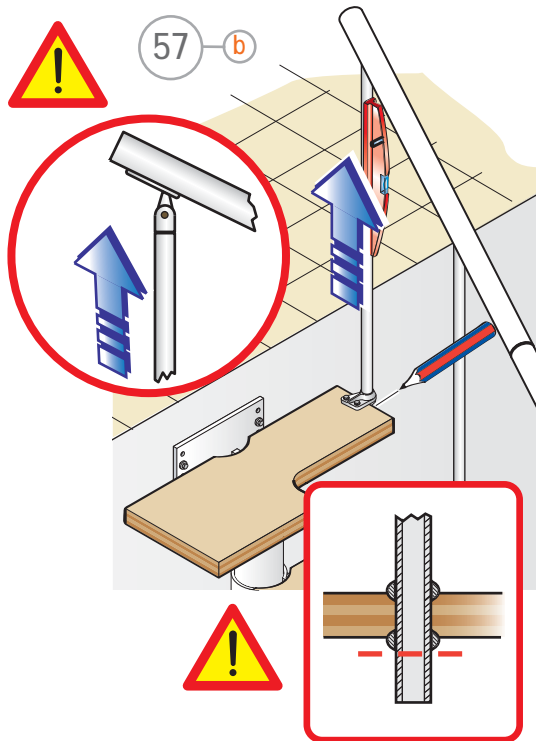
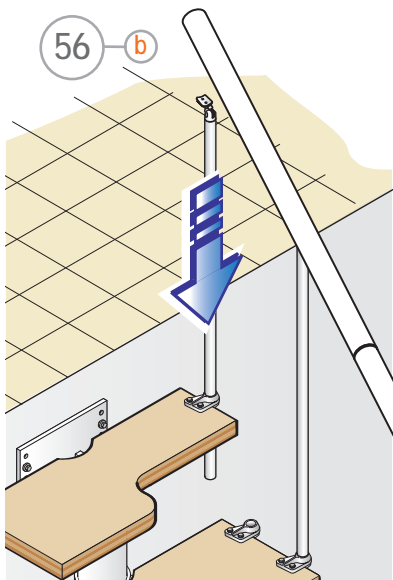

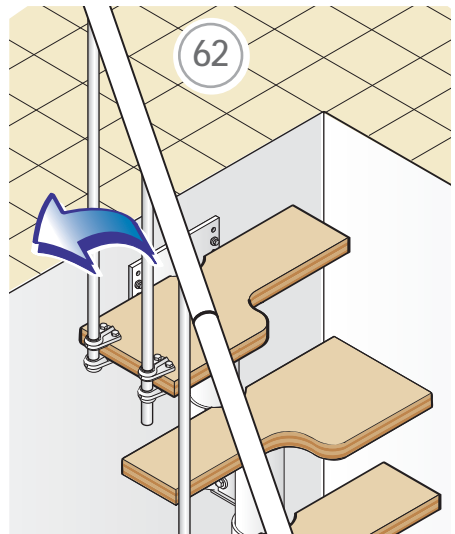
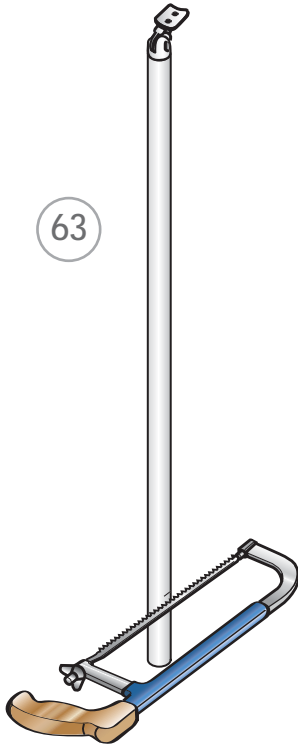
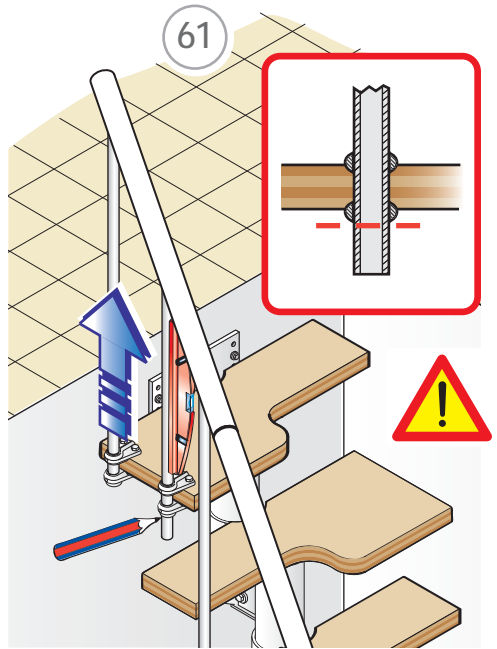
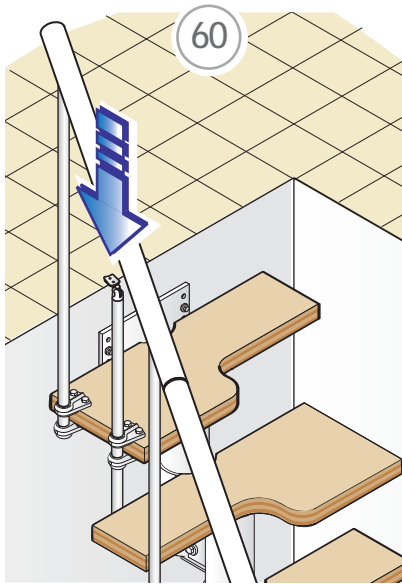

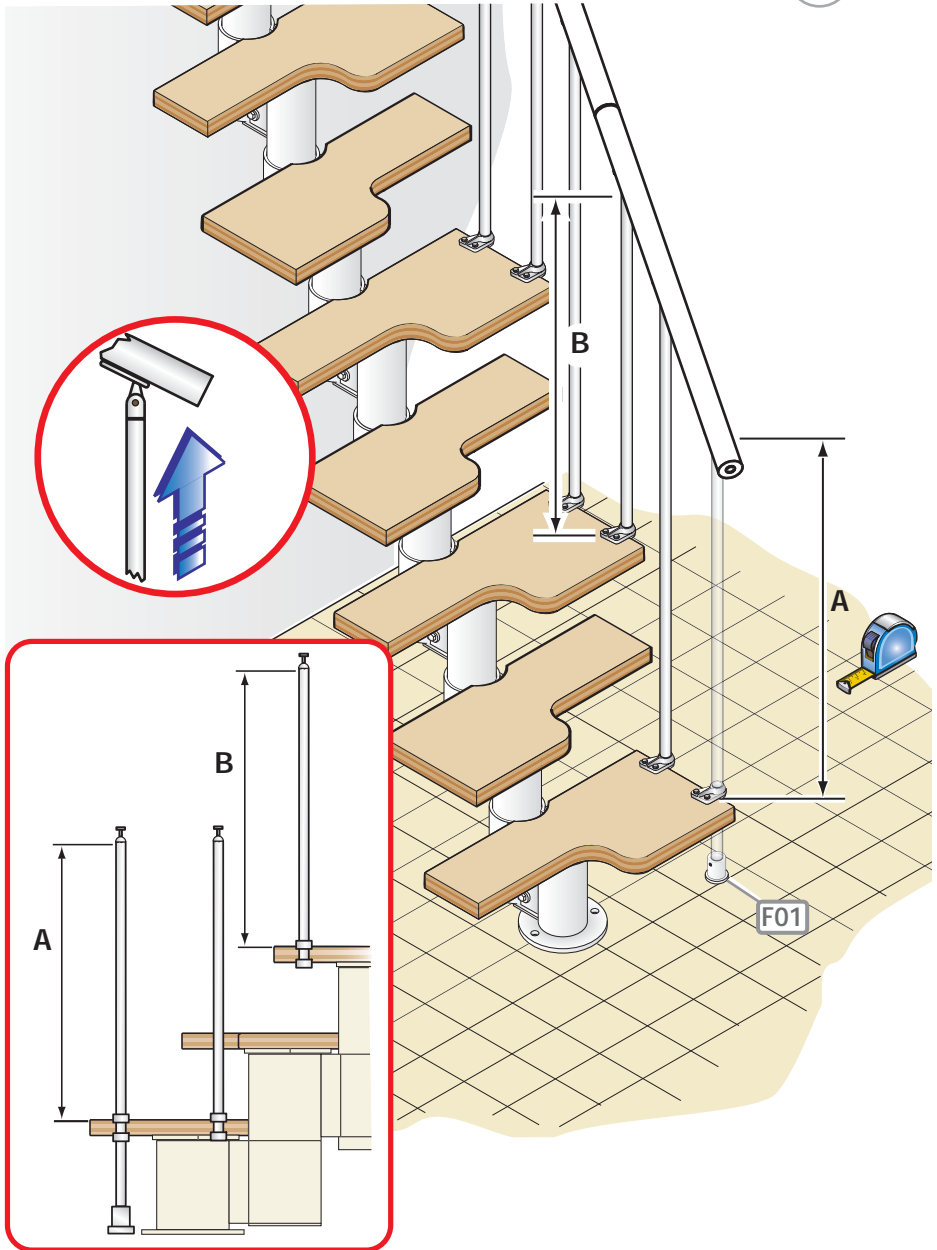

65 b

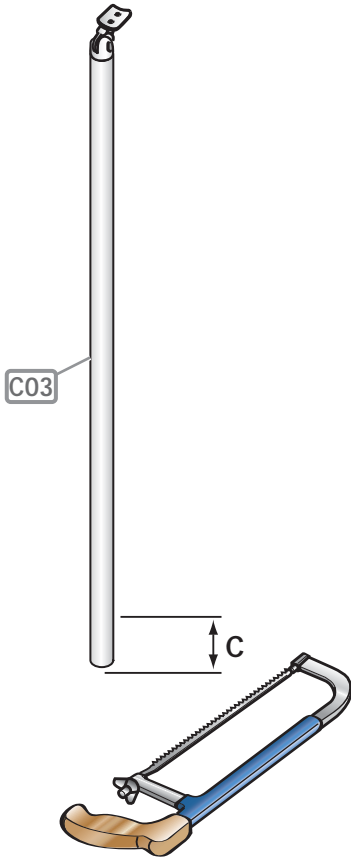

$$C = A - B$$

66 b

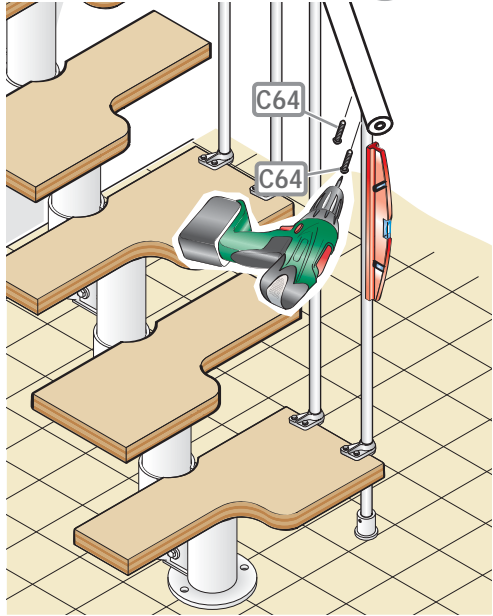

67

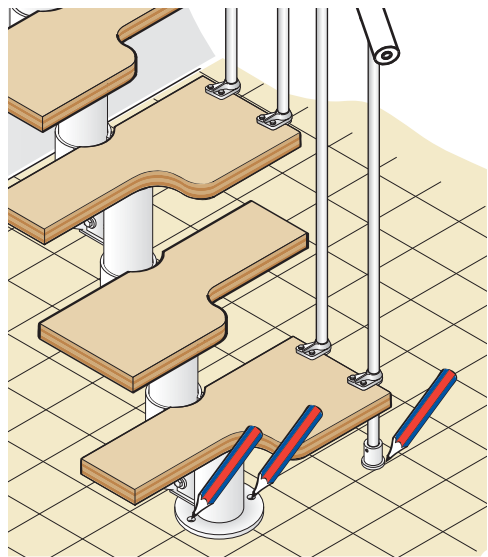

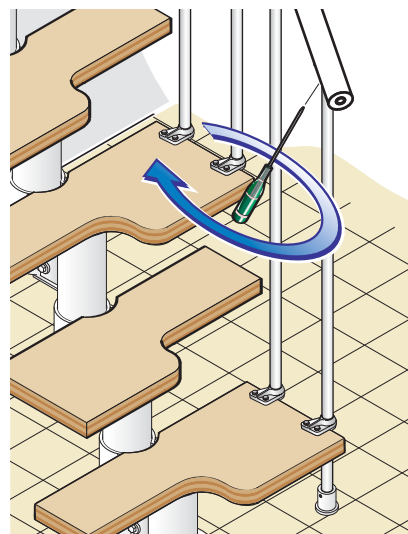
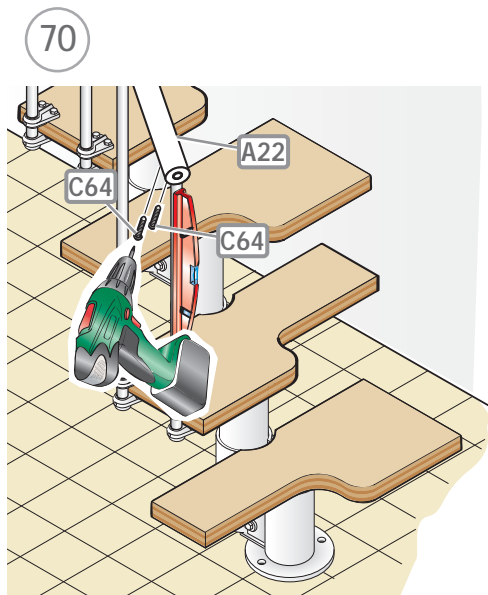
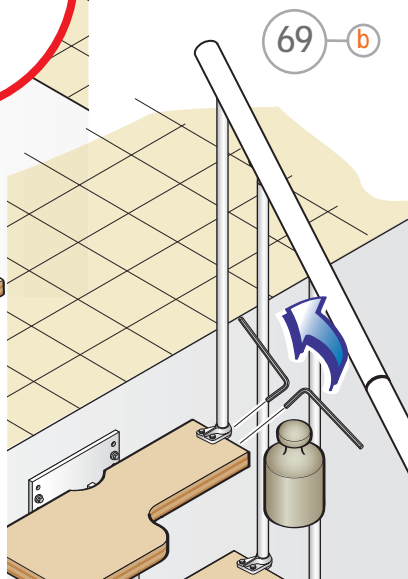
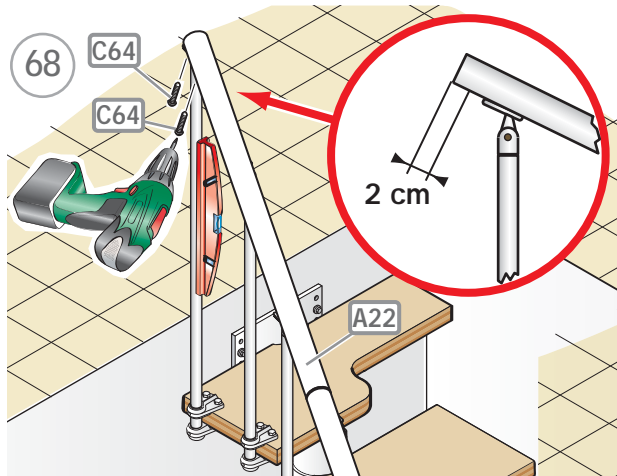

72 b

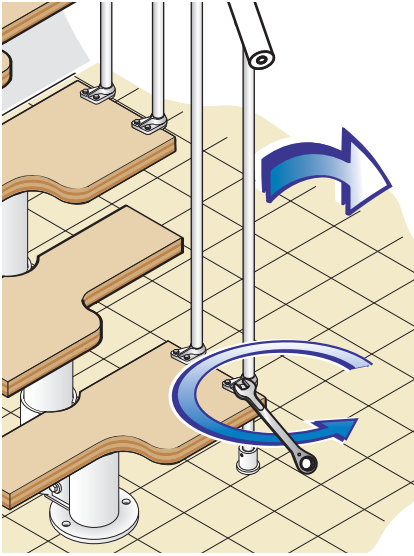

73

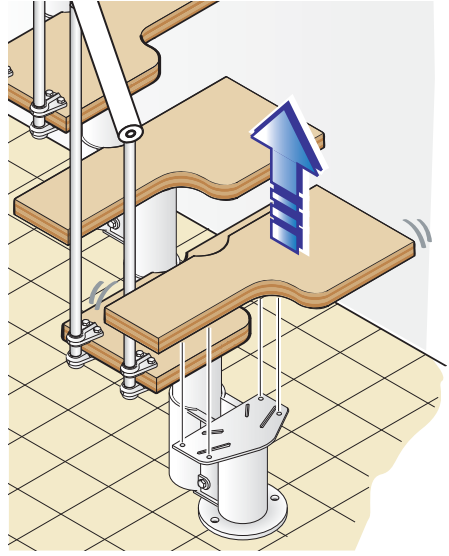

74

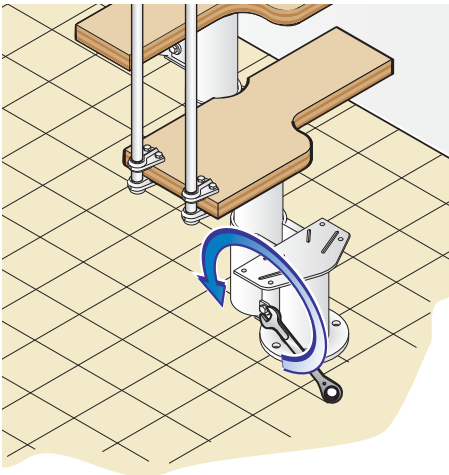

75

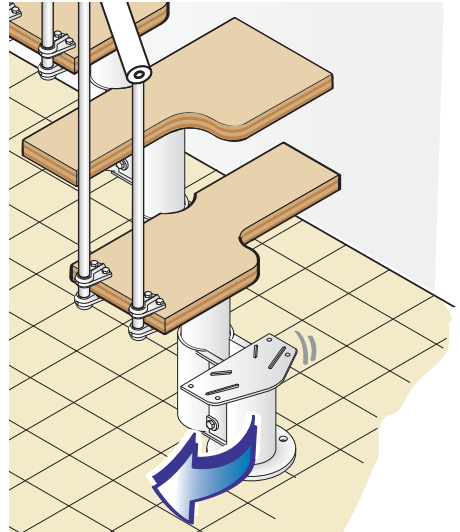

76 b

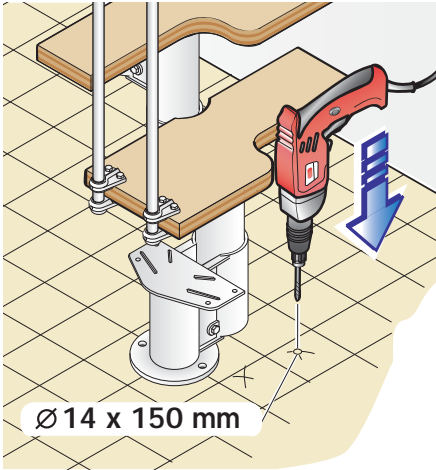

77

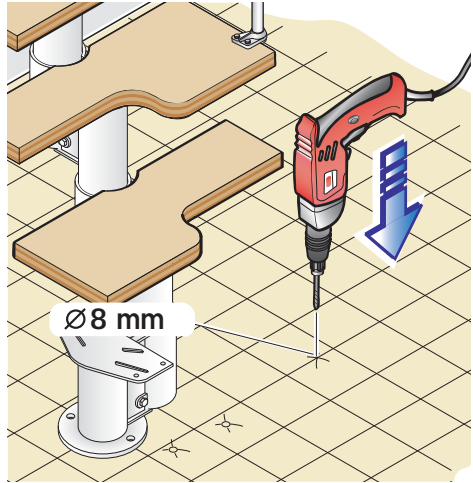

78

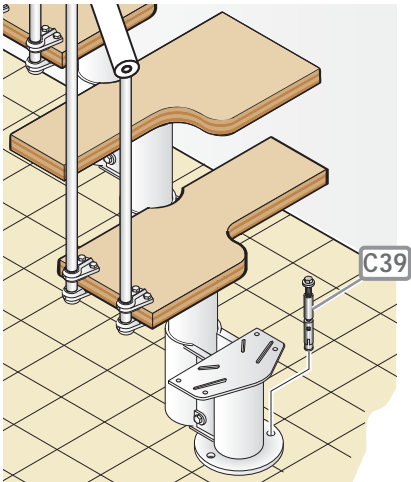

79

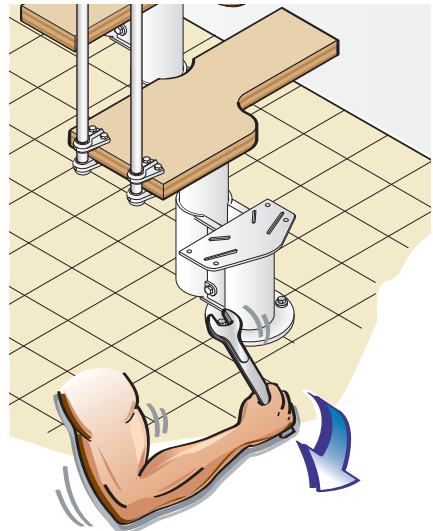

80



81 b

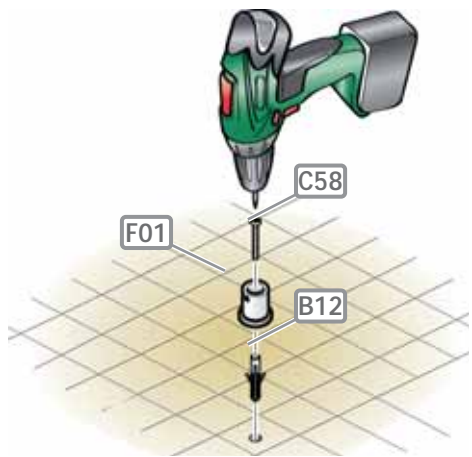

82

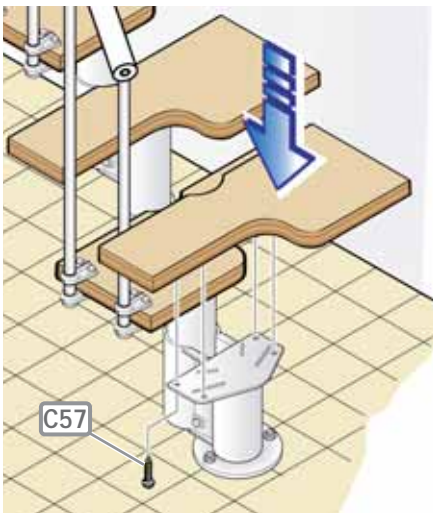

83 b

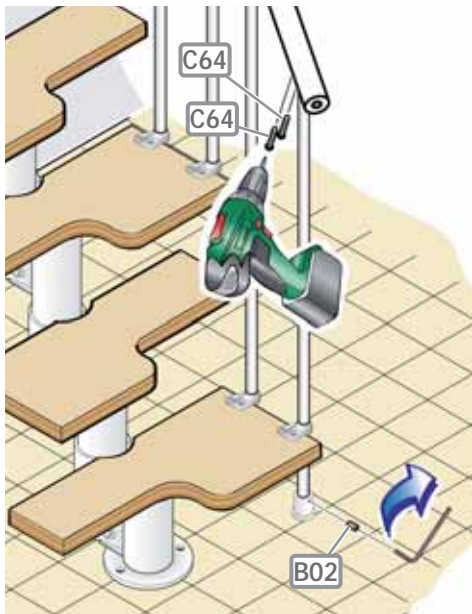

84 b

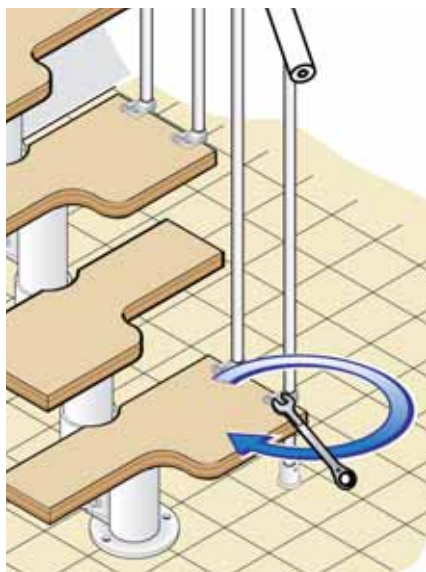

85 b

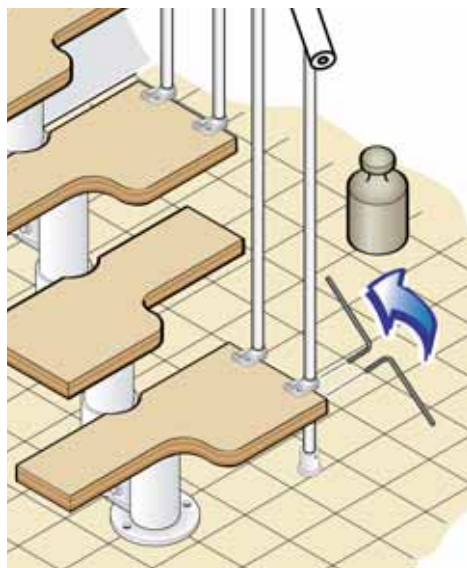

86

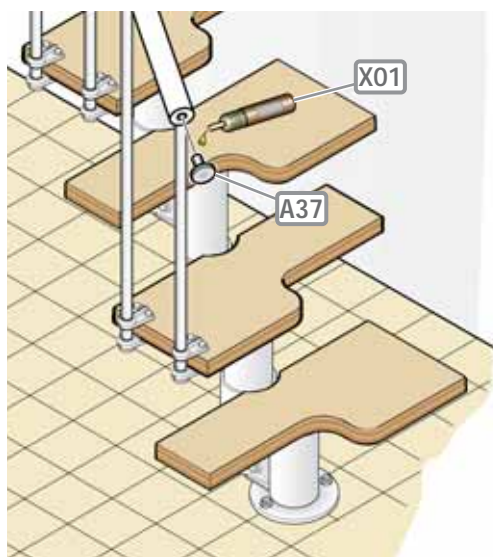

87

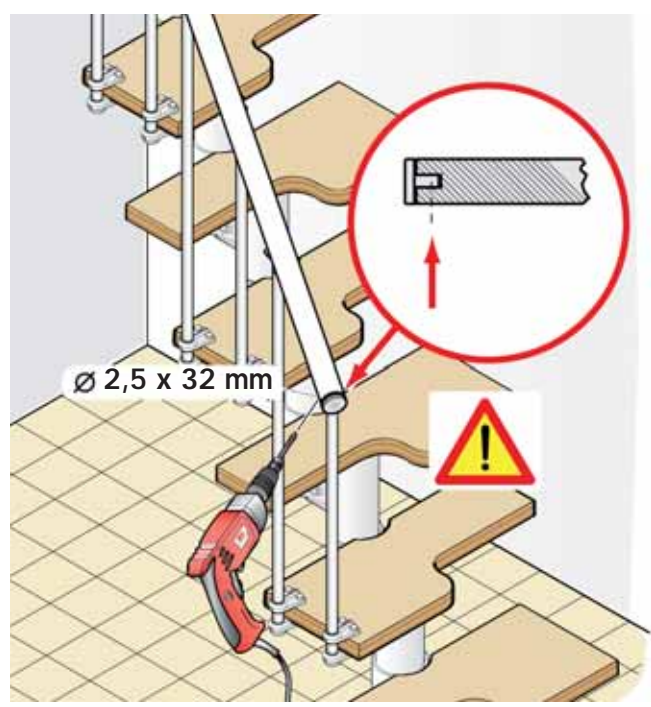

88

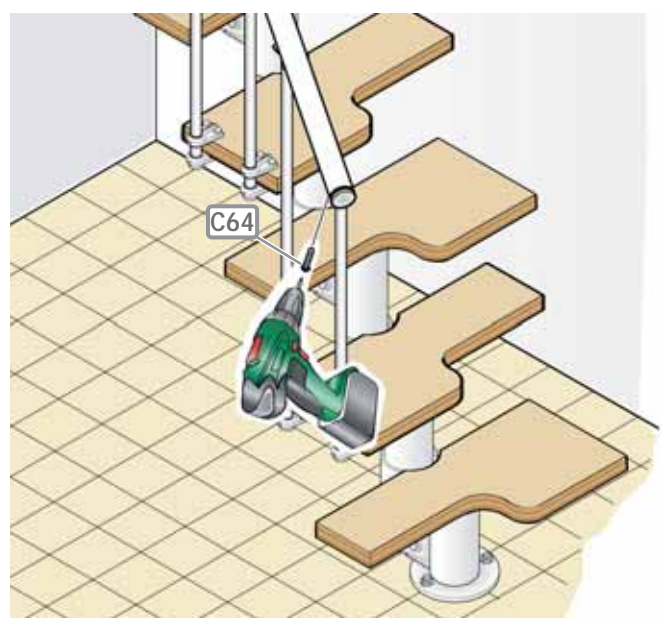

89

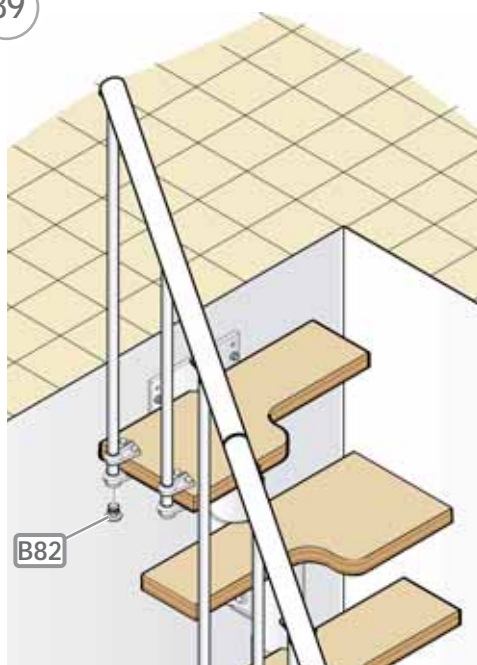

90

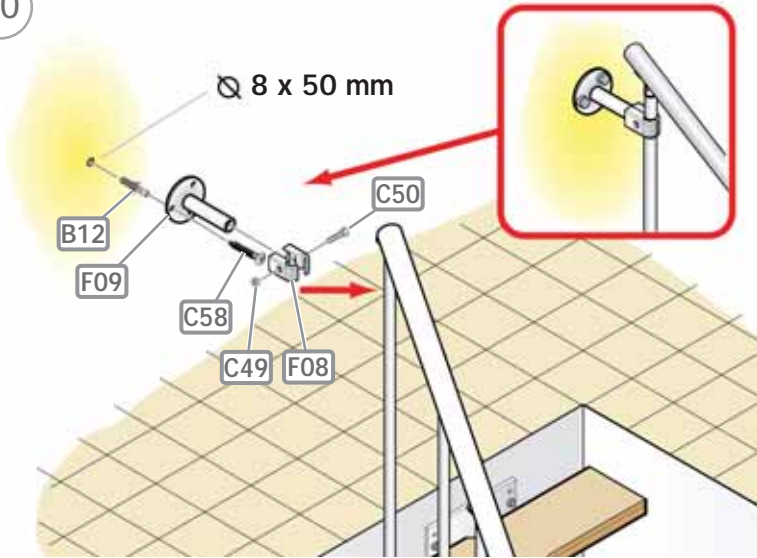

91

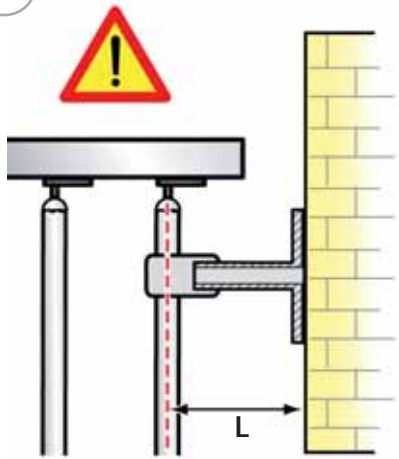

92

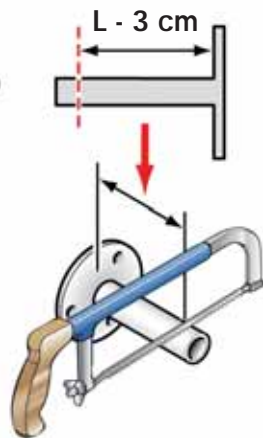



Italiano
English
Deutsch
Français
Español

DATI IDENTIFICATIVI DEL PRODOTTO
PRODUCT DETAILS
PRODUKTEIGENSCHAFTEN
DONNÉES D'IDENTIFICATION DU PRODUIT
DATOS DE IDENTIFICACIÓN



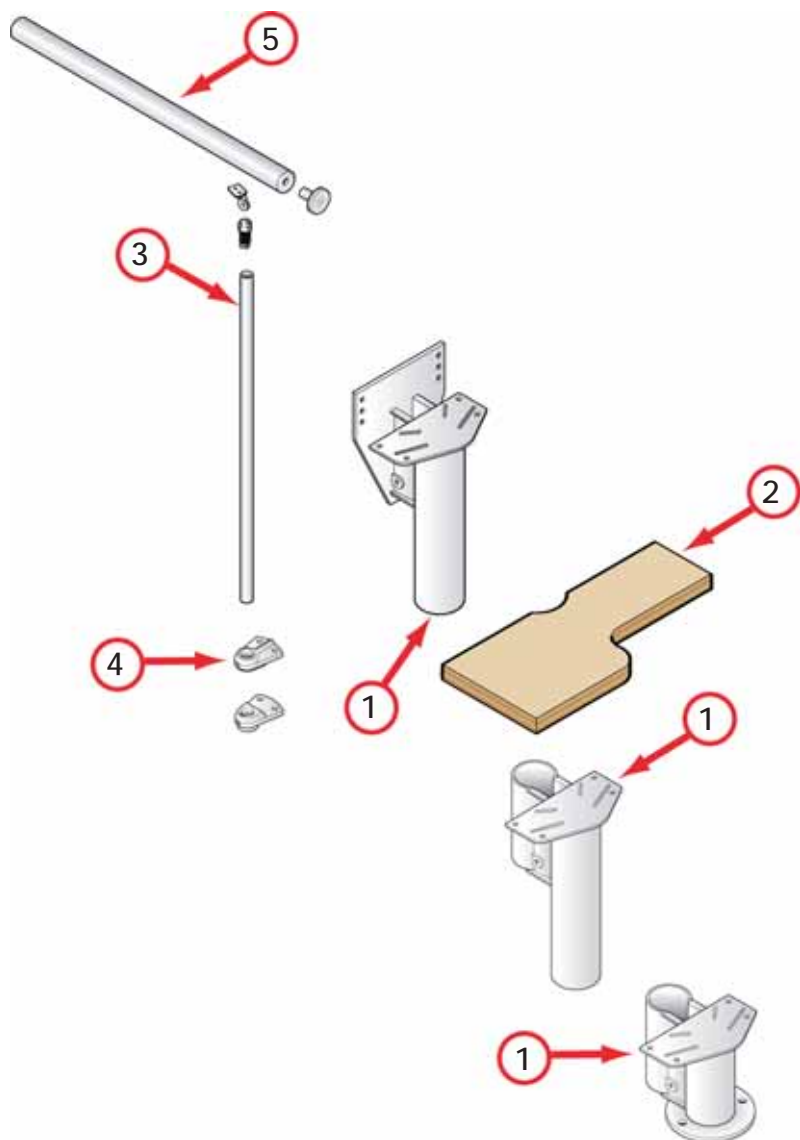

IT)

dati identificativi del prodotto

denominazione commerciale: **OAK 30**

tipologia: scala a giorno con gradini sfalsati e rotazione delle rampe con pendenza

materiali impiegati

STRUTTURA

descrizione

composta da elementi (1) metallici assemblati fra di loro con bulloni

materiali

Fe 370

finitura

verniciatura a forno con polveri epossidiche

GRADINI

descrizione

gradini (2) in legno sagomati assemblati alla struttura con bulloni

materiali

rovere

finitura

tinta: all'acqua

fondo: poliuretano

finitura: poliuretano

RINGHIERA

descrizione

composta da colonnine (3) verticali in metallo fissate ai gradini (2) e da corrimano (5) in PVC

materiali

colonnine (3): Fe 370

fissaggi (4): nylon

corrimano (5): PVC con anima di alluminio

finitura

colonnine (3): verniciatura a forno con polveri epossidiche

PULIZIA

pulire con panno morbido inumidito in acqua, privo di qualsiasi prodotto contenente solventi o materiali abrasivi.

MANUTENZIONE

dopo circa 12 mesi dalla data di installazione, controllare il serraggio della viteria dei vari componenti. la manutenzione straordinaria deve essere eseguita a regola d'arte.

PRECAUZIONI D'USO

evitare usi impropri e non consono al prodotto. eventuali manomissioni o installazioni non rispondenti alle istruzioni del produttore possono inficiare le conformità prestabilite del prodotto.

EN)

product details

trade name: **OAK 30**

type: flight staircase with alternate treads and flight rotation with slope

used materials

STRUCTURE

description

composed of metallic elements (1) assembled between themselves by bolts

materials

spacers: Fe 370

finishing

oven varnishing with epoxy powders

TREADS

description

wooden shaped treads (2) assembled to the structure by bolts

materials

oak

finishing

colour: water-base

undercoat: polyurethane

finishing: polyurethane

RAILING

description

composed by vertical metal balusters (3) fixed to the treads (2) and by a PVC handrail (5)

materials

balusters (3): Fe 370

fixings (4): nylon

handrail (5): PVC with aluminium core

finishing

balusters (3): oven varnishing with epoxy powders

CLEANING

clean with a soft wet cloth, without any product containing solvents or abrasive materials.

MAINTENANCE

about 12 months after the installation date, check the tightening of bolts on the various components. all non-routine maintenance procedures must be carried out in a strictly professional manner.

USE PRECAUTION

avoid any improper use that is not in accordance with the product. possible violations or installations which don't comply with the providers instructions can invalidate the agreed product conformities.

DE)

Produkteigenschaften

kommerzielle Bezeichnung: **OAK 30**

Typologie: Mittelholztreppe mit versetzten Stufen, Wendelung der Treppenläufe mit Neigung

verwendete Materialien

STRUKTUR

Beschreibung

bestehend aus Metallteilen (1) die miteinander durch Bolzen verbunden sind

Materialien

Fe 370

Ausführung

Pulverbeschichtung mit Epoxidharzen

STUFEN

Beschreibung

geformte Stufen (2) aus Holz an der Struktur mittels Bolzen befestigt

Materialien

Eichenholz

Ausführung

Beizung: Wasserfarbe

Grundierung: Polyurethan

Oberlack: Polyurethan

GELÄNDER

Beschreibung

bestehend aus senkrechten Geländerstäben (3) aus Metall, die an den Stufen (2) befestigt sind, und einem Handlauf (5) aus PVC

Materialien

Geländerstäbe (3): Fe 370

Befestigungen (4): Nylon

Handlauf (5): PVC mit Aluminiumkern

Ausführung

Geländerstäbe (3): Pulverbeschichtung mit Epoxidharzen

REINIGUNG

mit einem weichen feuchten Tuch reinigen. keine Reinigungsmittel verwenden, die Lösungsmittel- oder Scheuermittel beinhalten.

WARTUNG

ungefähr 12 Monate nach dem Einbau, die Festigkeit der einzelnen Schrauben überprüfen. die außerordentliche Wartung muss nach allen Regeln der Kunst ausgeführt werden.

VORSICHTSMAßNAHMEN FÜR DIE ANWENDUNG

die falsche und unangemessene Verwendung des Produkts vermeiden. eventuelle Beschädigungen oder nicht der Montageanleitung des Herstellers gemäße Einrichtungen können die vorgegebene Produktkonformität für ungültig erklären.

FR)

données d'identification du produit

denomination commerciale: **OAK 30**

typologie: escalier à volée avec marches décalées et rotation des volées en pente

matériaux utilisés

STRUCTURE

description

composée d'éléments (1) métalliques assemblés entre eux par boulonnage

matériaux

Fe 370

finition

vernissage à chaud avec poudres époxy

MARCHES

description

marches façonnées (2) en bois assemblées à la structure par boulonnage

matériaux

chêne

finition

vernis: à l'eau

mordant: polyuréthanique

finition: polyuréthanique

GARDE-CORPS

description

composé de colonnettes (3) verticales en métal fixées aux marches (2) et d'une main courante (5) en PVC

matériaux

colonnettes (3): Fe 370

fixations (4): nylon

main courante (5): PVC avec noyau en aluminium

finition

colonnettes (3): vernissage à chaud avec poudres époxy

NETTOYAGE

nettoyer avec un chiffon souplé humidifié à l'eau, sans aucun produit contenant des solvants ou matières abrasives.

ENTRETIEN

après environ 12 mois de la date d'installation, contrôler le serrage de la visserie et des différents éléments. l'entretien extraordinaire doit être exécuté dans les règles de l'art.

PRECAUTION D'UTILISATION

éviter l'utilisation impropre et non conforme au produit. d'éventuelles alterations ou installations non correspondantes aux instructions du producteur peuvent invalider les conformités préétablies du produit.

ES)

datos de identificación del producto

denominación comercial: **OAK 30**

tipo: escalera abierta con peldaños de paso alternado y rotación de los tramos con pendiente

materiales empleados

ESTRUCTURA

descripción

compuesta por elementos **(1)** metálicos ensamblados entre ellos mediante pernos

materiales

Fe 370

acabado

barnizado en horno con polvos epoxídicos

PELDAÑOS

descripción

peldaños **(2)** de madera perfilados y ensamblados a la estructura mediante pernos

materiales

roble

acabado

barniz: al agua

imprimación: poliuretánica

acabado: poliuretánico

BARANDILLA

descripción

compuesta por barrotes **(3)** verticales de metal fijados a los peldaños **(2)** y por un pasamanos **(5)** de PVC

materiales

barrotes **(3)**: Fe 370

fijaciones **(4)**: nylon

pasamanos **(5)**: PVC con alma de aluminio

acabado

barrotes **(3)**: barnizado en horno con polvos epoxídicos

LIMPIEZA

limpiar con un trapo suave humedecido con agua y sin ningún producto que contenga disolventes o materiales abrasivos.

MANTENIMIENTO

transcurridos unos 12 meses desde la fecha de instalación, comprobar que los tornillos que fijan las distintas partes sigan bien apretados. el mantenimiento extraordinario debe ser efectuado como corresponde.

PRECAUCIONES DE USO

evitar usos impropios y no conformes con el producto. eventuales manipulaciones o instalaciones que no cumplan con las instrucciones del fabricante pueden menoscabar las cualidades certificadas en las pruebas de conformidad a las que previamente fue sometido el producto.



Oak30
D.U.M.
07/2013

fontanot®

Albini & Fontanot S.p.A.
Sede legale ed amministrativa
via P. Paolo Pasolini, 6
47853 Cerasolo Ausa
Rimini, Italy

tel. +39.0541.90.61.11
fax. +39.0541.90.61.24
info@fontanot.it
www.fontanot.it

cod. 066726000

Design: Centro Ricerche Fontanot

ADIMEMBER

Sistema aziendale Albini & Fontanot S.p.A.
certificato CSQ ISO-9001

